



User Manual

DRS-100-1P

DIN Rail Energy Meter for Direct Connected Single Phase Electrical Systems up to 100 Amps

Warnings

Caution: Risk of Electric Shock

- During normal operation, voltages hazardous to life may be present at some of the terminals of this unit.
- At voltages below that specified in the Range of Use the meter may shut down. However, voltages hazardous to life may still be present at some of the terminals of this unit.
- Installation and servicing should be performed only by qualified, properly trained personnel abiding by local regulations.
- Ensure all supplies are de-energised before attempting connection or other procedures.
- Terminals should not be user accessible after installation and external installation provisions must be sufficient to prevent hazards under fault conditions.
- This unit is not intended to function as part of a system providing the sole means of fault protection - good engineering practice dictates that any critical function be protected by at least two independent and diverse means.
- The unit does not have internal fuses therefore external fuses must be used for protection and safety under fault conditions.
- Never open-circuit the secondary winding of an energized current transformer.
- This product should only be operated with the CT secondary connections earthed.
- If this equipment is used in a manner not specified by the manufacturer, protection provided by the equipment may be impaired.

Warnings

Important Safety Information is contained in the Maintenance section. Familiarize yourself with this information before attempting installation or other procedures. Symbols used in this document:

Risk of Danger: These instructions contain important safety information. Read them before starting installation or servicing of the equipment.

Caution: Risk of Electric Shock

1 Introduction

The Multifunction Energy Meter, DRS-100-1P, is a new generation DIN rail mounted meter, used not only in the electricity transmission and power distribution system but also in power consumption measurement and analysis in high voltage intelligent power grid.

This document provides operating, maintenance and installation instructions for the DRS-100-1P. The unit measures and displays the characteristics of single phase two wire supplies including voltage, frequency, current, power, active and reactive energy, imported or exported. Energy is measured in kWh and kVAh. Maximum demand power can be measured over preset periods of up to 60 minutes.

The DRS-100-1P features two built-in pulsed outputs and RS485 Modbus RTU comms. Configuration is password protected.

1.1 Unit Characteristics

The DRS-100-1P can measure and display:

- Voltage
- Frequency
- Current
- Power, Maximum Demand Power and Power Factor
- Imported, Exported & Total Active Energy
- Imported, Exported & Total Reactive Energy

The unit has a Password-Protected set up menu for:

- Changing the Password
- Demand Interval Time
- Reset for Demand Measurements
- Pulse Output Duration

A pulsed output indicates real-time energy measurement. An RS485 output allows remote monitoring from another display or a computer.

1.2 RS485 Serial – Modbus RTU

This uses an RS485 serial port with Modbus RTU protocol to provide a means of remotely monitoring and controlling the DRS-100-1P. Set-up screens are provided for setting up the RS485 port. See section 4.3.

1.3 Pulse output

This unit has 2 built-in pulsed outputs that record measured active and reactive energy. The constant for reactive energy is 5000imp/kVAh. The pulse width for active energy can be set from the Set-up menu.

2 Start Up Screens



The first screen lights all display segments and can be used as a display check.

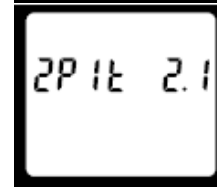

The second screen indicates the firmware installed in the unit and its build number.

Please note: The values may vary from the numbers shown here.



Next the unit will display the set Modbus address.



Finally the meter will display the configured baud rate.

*After a short delay, the screen will display the total active energy measurement.

3 Buttons

The buttons operate as follows:



This is the button used to rotate through the different parameter options. This is also the button used to cycle through numbers when in selection mode. Holding this button when in selection mode will exit selection without saving.



This is the button that is held to enter an input, to confirm your selection change and to access the set up menu. This is also the button used to move right when in selection mode.

3.1 Measurements

Each successive press of the button selects a new parameter:



Total active energy (Σ kWh).



Imported active energy (kWh).



Exported active energy (kWh).



Partial active energy (Σ r kWh).



Total reactive energy (Σ kVAh).



Imported reactive energy (kVAh).



Exported reactive energy (kVAh).



Partial reactive energy (Σ r kVAh).

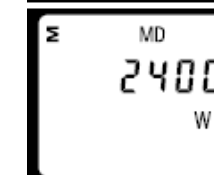

Total Maximum Demand (W).



Voltage Input (V).



Current Input (A).



Instantaneous Active Power (W).

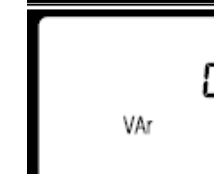

Instantaneous Reactive Power (VAr).



Instantaneous Apparent Power (VA).



Power Factor.

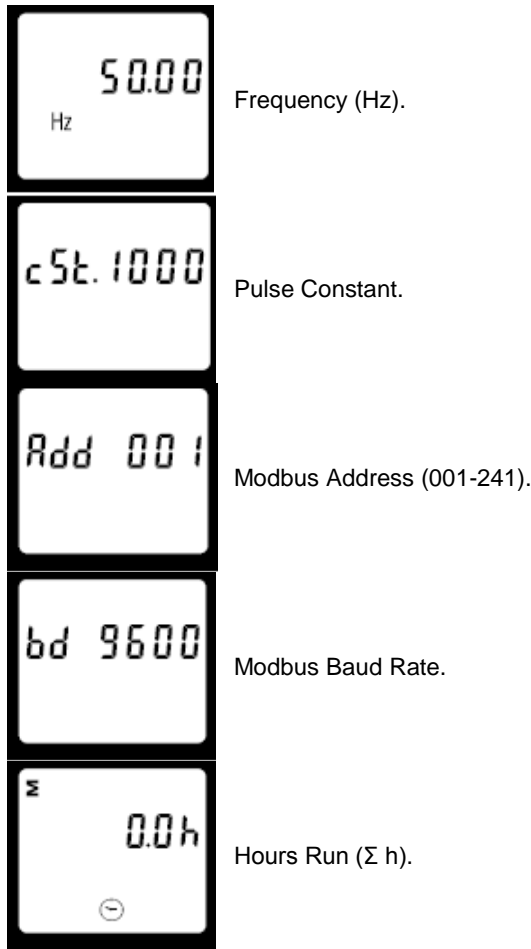

Frequency (Hz).

Pulse Constant.

Modbus Address (001-241).

Modbus Baud Rate.

Hours Run (Σ h).

4 Set Up

To enter set-up mode, press the button for 3 seconds, until the password screen appears.

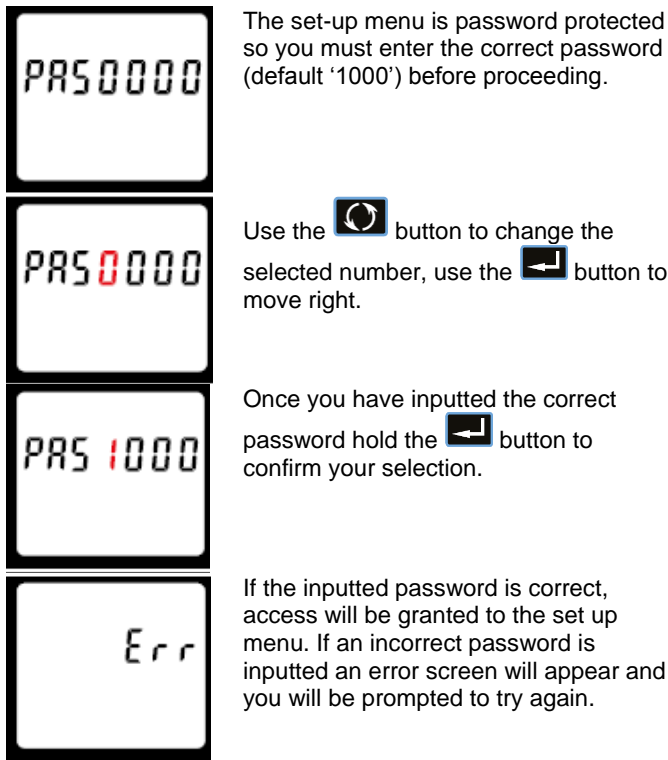

The set-up menu is password protected so you must enter the correct password (default '1000') before proceeding.

Use the button to change the selected number, use the button to move right.

Once you have inputted the correct password hold the button to confirm your selection.

If the inputted password is correct, access will be granted to the set up menu. If an incorrect password is inputted an error screen will appear and you will be prompted to try again.

To exit the set-up menu, press & hold until the measurement screen is restored.

4.1 Menu Option Selection

1. Use the button to scroll through to the required item in the menu. The menu scrolls through on a loop.
2. Once on the desired menu option, press & hold to confirm your selection.
3. If an item flashes, then it can be adjusted by the button. If not, there may be a further layer.
4. Once you have changed the selection to the desired option, press & hold to confirm your selection. Once the option stops flashing it will set.
5. Having completed a parameter setting, press & hold the button to exit the set-up menu.

4.2 Number Entry Procedure

When setting up the unit, some screens require the entering of a number. In particular, on entry to the set-up menu, a password must be entered. Digits are set individually, from left to right. The procedure is as follows:

1. The current digit to be set will start flashing and is set using the button.
2. Press to move right to the next digit.
3. After setting the last digit, press & hold the button to confirm the change.

4.3 Set Modbus Address

This sets the Modbus address of the specific meter so that clients using a Modbus system can differentiate between meters. Available options are 001-241

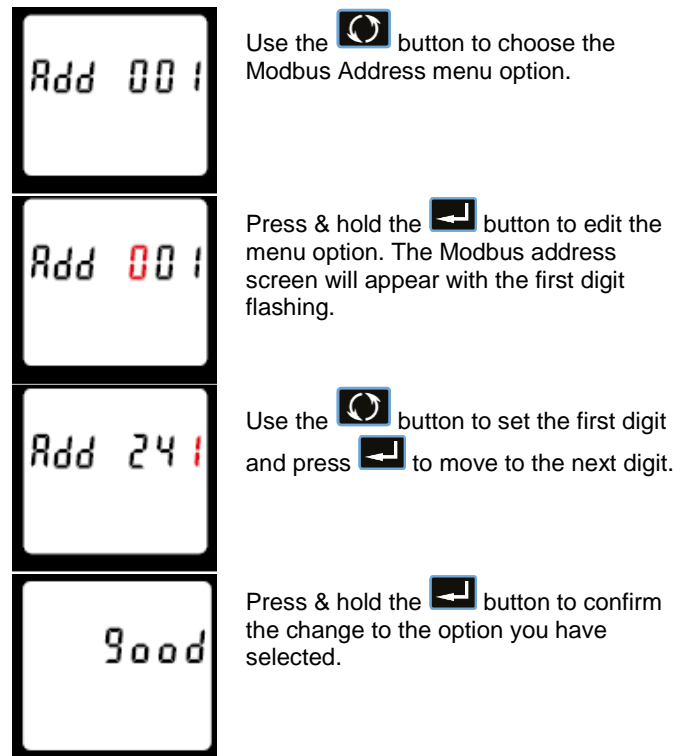

Use the button to choose the Modbus Address menu option.

Press & hold the button to edit the menu option. The Modbus address screen will appear with the first digit flashing.

Use the button to set the first digit and press to move to the next digit.

Press & hold the button to confirm the change to the option you have selected.

To exit the set-up menu, press & hold until the measurement screen is restored.

4.4 Set Baud Rate

The baud rate of a data communications system is the number of symbols per second transferred.

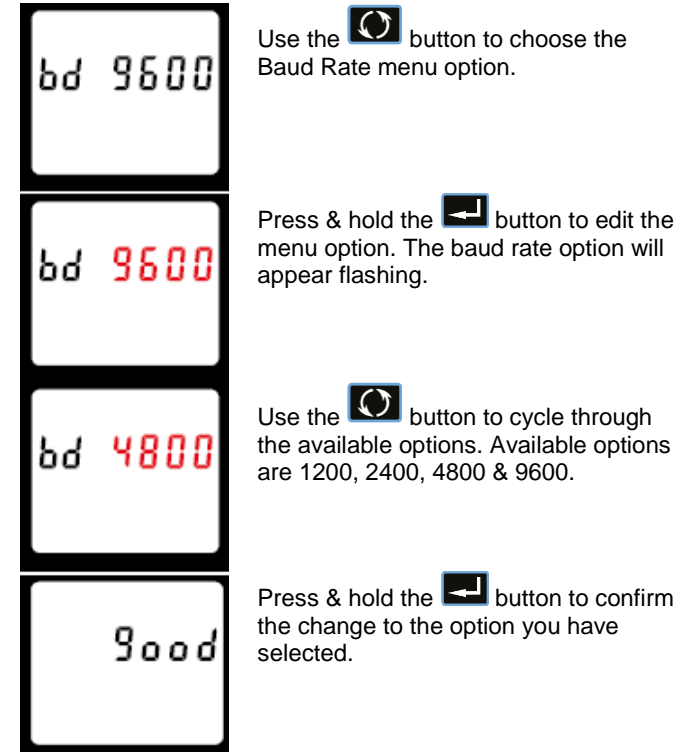

Use the button to choose the Baud Rate menu option.

Press & hold the button to edit the menu option. The baud rate option will appear flashing.

Use the button to cycle through the available options. Available options are 1200, 2400, 4800 & 9600.

Press & hold the button to confirm the change to the option you have selected.

To exit the set-up menu, press & hold until the measurement screen is restored.

4.5 Set Parity

Available options are none (N), even (E) & odd (O).

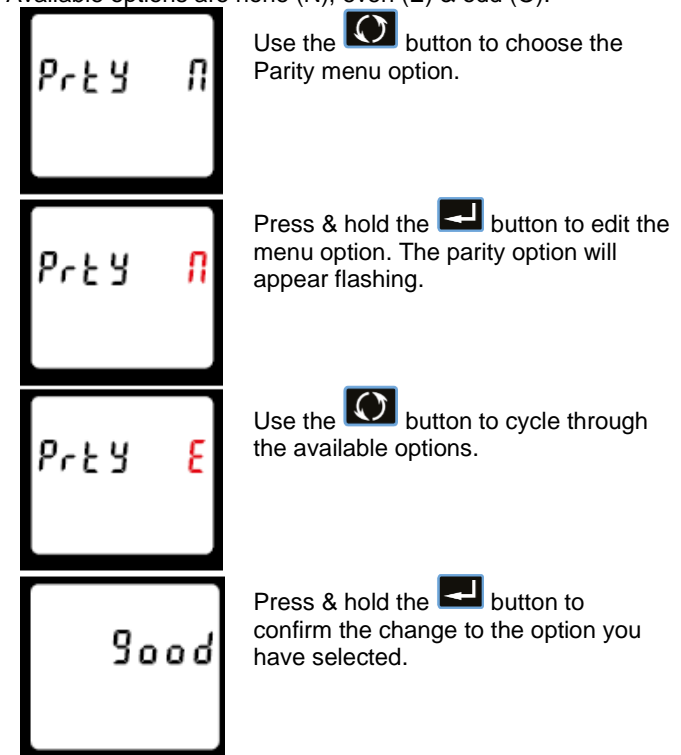

Use the button to choose the Parity menu option.

Press & hold the button to edit the menu option. The parity option will appear flashing.

Use the button to cycle through the available options.

Press & hold the button to confirm the change to the option you have selected.

To exit the set-up menu, press & hold until the measurement screen is restored.

4.6 Set Pulsed Output

The DRS-100-1P comes with 2 built-in pulsed outputs. One of the pulsed outputs is settable by the user, the other pulsed output is fixed. Available options for editable pulsed outputs are kWh, kVArh, Import kWh, Export kWh, Import kVArh & Export kVArh.

Please note there are limitations that need to be factored in when setting the pulsed output. This is based upon the relay output only being able to pulse 2 times in one second.

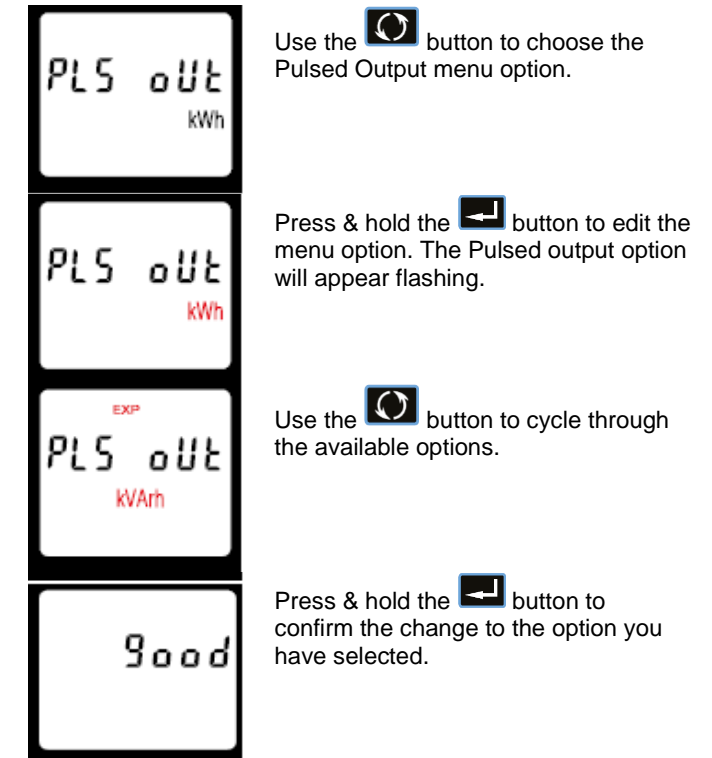

Use the button to choose the Pulsed Output menu option.

Press & hold the button to edit the menu option. The Pulsed output option will appear flashing.

Use the button to cycle through the available options.

Press & hold the button to confirm the change to the option you have selected.

To exit the set-up menu, press & hold until the measurement screen is restored.

4.7 Set Pulse Constant

The Pulse Constant is the menu setting that allows you to set how many times the meter will pulse to produce 1 pulsed output. Available options are 1, 10, 100 & 1000. For example, if you have set the Pulsed Output (see 4.4) to kWh, and the Pulse Constant is set to 10, the meter will pulse 10 times per kWh pulsed output.

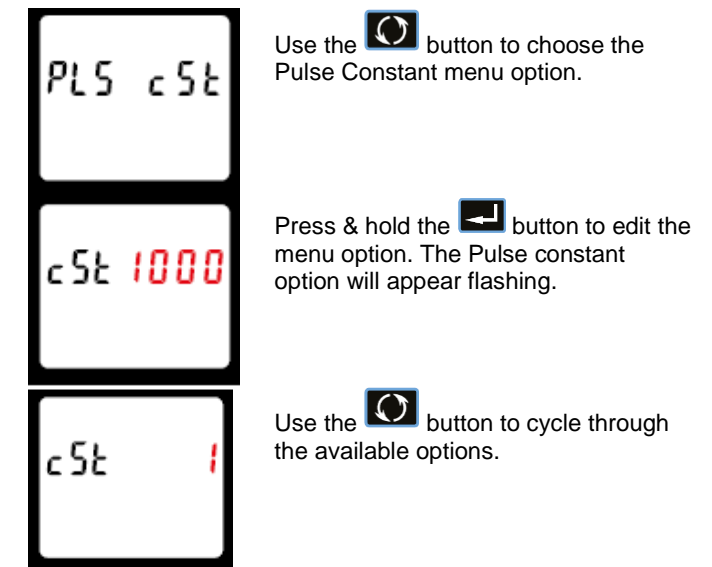

Use the button to choose the Pulse Constant menu option.

Press & hold the button to edit the menu option. The Pulse constant option will appear flashing.

Use the button to cycle through the available options.



Press & hold the button to confirm the change to the option you have selected.

To exit the set-up menu, press & hold until the measurement screen is restored.

4.8 Set Pulse Duration

The Pulse Duration option that allows you to set how long the contact of the pulse is open for per pulse. Available options are 60, 100 & 200mS.

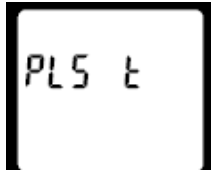

Use the button to choose the Baud Rate menu option.



Press & hold the button to edit the menu option. The Pulse duration option will appear flashing.



Use the button to cycle through the available options.



Press & hold the button to confirm the change to the option you have selected.

To exit the set-up menu, press & hold until the measurement screen is restored.

4.9 DIT - Demand Integration Time

This sets the period in minutes over which the power readings are integrated for maximum demand measurement. The options are: off, 5, 10,15 30,60 minutes.



Use the button to choose the DIT SET menu option.



Press & hold the button to edit the menu option. The screen will display a flashing number.



Use the button to cycle through the available options.



Press & hold the button to confirm the change to the option you have selected.

To exit the set-up menu, press & hold until the measurement screen is restored.

4.10 Automatic Scroll Time Interval

Use this section to set the time interval (in seconds) for the meter to scroll through the different parameters.

The available options range from 0-30 seconds.



Use the button to choose the Scrl T menu option.



Press & hold the button to edit the menu option. The screen will display a flashing number.



Use the button to cycle through the available options.



Press & hold the button to confirm the change to the option you have selected.

To exit the set-up menu, press & hold until the measurement screen is restored.

4.11 LP - Light Period

This sets the period in minutes over which the backlight on the meter stays on for.



Use the button to choose the LP SET menu option.



Press & hold the button to edit the menu option. The screen will display a flashing number.



Use the button to cycle through the available options. The options are: off, 5, 10,15 30,60 minutes. The option OFF means that the backlight stays on continuously.



Press & hold the button to confirm the change to the option you have selected.

To exit the set-up menu, press & hold until the measurement screen is restored.

4.12 Reset (Clr)

Within this menu option, you can clear the Maximum Demand Power (W), you can reset the Partial Active Energy (Σ kWh) and the Partial Reactive Energy (Σ kVARh).



Use the button to choose the Clear menu option.

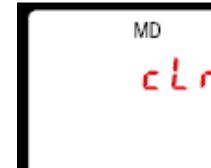

Press & hold the button to edit the menu option. The first option will appear flashing.



Use the button to cycle through the available options.



Press & hold the button to confirm the selection. Once the meter has cleared the reading, it will appear saying "good".

To exit the set-up menu, press & hold until the measurement screen is restored.

4.13 Change Password



Use the button to choose the change password option.



Press & hold the button to edit the password. The new password screen will appear with the first digit flashing.



Use the button to set the first digit and press to move to the next digit.



Repeat the procedure for the remaining three digits.



After setting the last digit, press & hold the button to confirm your change.

To exit the set-up menu, press & hold until the measurement screen is restored.

5 Specifications

The DRS-100-1P can monitor and display the following parameters of a single phase supply:

5.1.1 Voltage and Current

- Phase to neutral voltage 176 to 276V AC.
- Continuous Overload voltage 120%
- Phase current to 100A
- Continuous Overload current 120%
- Burden <10VA (nom 2VA)
- Self powered from any phase

5.1.2 Power factor and Frequency and Max. Demand

- Frequency in Hz
- Instantaneous Power 0 to 999MW
- Reactive Power 0 to 999MVAR
- Volt-amps 0 to 999 MVA
- Maximum demanded power since last Demand reset Power factor

5.1.3 Energy Measurements

- Imported active energy 0 to 99999.9 kWh
- Exported active energy 0 to 99999.9 kWh
- Imported reactive energy 0 to 99999.9 kVARh
- Exported reactive energy 0 to 99999.9 kVARh
- Total active energy 0 to 99999.9 kWh
- Total reactive energy 0 to 99999.9 kVARh

5.2 Accuracy

- | | |
|-------------------------------|--|
| • Voltage | 0-5% of range maximum |
| • Current | 0-5% of nominal |
| • Frequency | 0-2% of mid-frequency |
| • Power factor | 1% of unity (0.01) |
| • Active power (W) | ±1% of range maximum |
| • Reactive power (VAR) | ±2% of range maximum |
| • Apparent power (VA) | ±1% of range maximum |
| • Active energy (Wh) | ±1% of range maximum |
| • Reactive energy VARh) | ±2% of range maximum |
| • Total harmonic distortion | 1% up to 31st harmonic |
| • Temperature co-efficient | 0.013%/°C typical |
| • Response time to step input | 1s, typical, to >99% of final reading, at 50 Hz. |

5.3 Interfaces for External Monitoring

Three interfaces are provided:

- RS485 communication channel that can be programmed for Modbus RTU protocol
- Relay output indicating real-time measured energy. (configurable)
- Pulse output 5000imp/kWh (not configurable)

The Modbus configuration (Baud rate etc.) and the pulse relay output assignments (kW/kVAh, import/export etc.) are configured through the Set-up screens.

5.4.1 Pulse Relay Output

The pulse relay output can be set to generate pulses to represent kWh or kVAh.

Rate can be set to generate 1 pulse per:

- 1 = 1 kWh/kVAh
- 10 = 10 kWh/kVAh
- 100 = 100 kWh/kVAh
- 1000 = 1000 kWh/kVAh

Pulse width 200/100/60 ms. Relay Rating 240V ac 50mA

5.4.2 RS485 Output for Modbus RTU

For Modbus RTU, the following RS485 communication parameters can be configured from the set-up menu:

Baud rate 1200, 2400, 4800, 9600,

Parity none / odd / even

RS485 network address 3-digit number, 1 to 247

Modbus™ Word order Hi/Lo byte order is set automatically to normal as defined in IEEE 754. It cannot be configured from the set-up menu.

5.5 Reference Conditions of Influence Quantities

Influence Quantities are variables that affect measurement errors to a minor degree. Accuracy is verified under nominal value (within the specified tolerance) of these conditions.

- Ambient temperature 23°C ±1°C
- Input waveform 50 or 60Hz ±2%
- Input waveform Sinusoidal (distortion factor < 0.005)
- Magnetic field of external origin Terrestrial flux

5.6 Environment

- Operating temperature -25°C to +55°C*
- Storage temperature -40°C to +70°C*
- Relative humidity 0 to 90%, non-condensing
- Altitude Up to 2000m
- Warm up time 1 minute
- Vibration 10Hz to 50Hz, IEC 60068-2-6, 2g
- Shock 30g in 3 planes

*Maximum operating and storage temperatures are in the context of typical daily and seasonal variation.

5.7 Mechanics

- DIN rail dimensions 76 x 100 mm (WxH) per DIN 43880
- Mounting DIN rail (DIN 43880)
- Sealing IP51 indoor
- Material UL 94 V-0 Self-extinguishing

6 Installation and Maintenance

6.1 Installation notes

Units should be installed in a dry position, where the ambient temperature is reasonably stable and will not be outside the range -25 to +55°C. Vibration should be kept to a minimum. Preferably, mount the Integra so that the display contrast is not reduced by direct sunlight or other high intensity lighting.

6.2 Input Wiring and Fusing

Choose fuses of a type and with a breaking capacity appropriate to the supply and in accordance with local regulations.

A switch or circuit breaker allowing isolation of supplies to the unit must be provided where practical. In primary metering applications, ensure the supply is isolated before any maintenance on the product. Tampering with the product seals may contravene local laws.

6.3 Wire Size

Voltage and current terminal blocks will accept 2.5mm² to 25mm² stranded cable.

6.4 Maintenance

The front of the case should be wiped with a dry cloth only, using minimal pressure. If necessary wipe the rear case with a dry cloth.

No user serviceable parts.

7 Declaration of Conformity

We, Tyco Electronics UK Ltd, declare under our sole responsibility as the manufacturer that the single phase multifunction electrical energy meter “DRS-100-1P”, corresponds to the production model described in the EC-type examination certificate and to the requirements of the Directive 2004/22/EC EC type examination certificate number 0120/SGS0249. Identification number of the NB 0120.

8 Meter

8.1 Dimensions

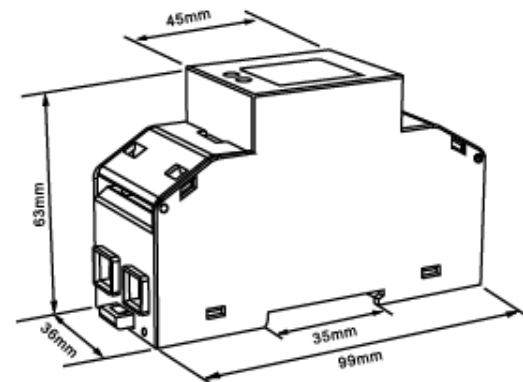

8.2 Appearance



9 Wiring Diagram

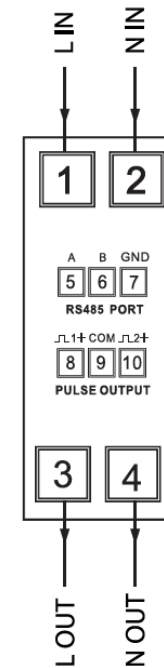

Explanation of Symbols

- Refer to manual
- Danger of electric shock
- Do not discard

While TE has made every reasonable effort to ensure the accuracy of the information in this catalogue, TE does not guarantee that it is error-free, nor does TE make any other representation, warranty or guarantee that the information is accurate, correct, reliable or current. TE reserves the right to make any adjustments to the information contained herein at any time without notice. TE expressly disclaims all implied warranties regarding the information contained herein, including, but not limited to, any implied warranties of merchantability or fitness for a particular purpose. The dimensions in this catalogue are for reference purposes only and are subject to change without notice. Specifications are subject to change without notice. Consult TE for the latest dimensions and design specifications. TE connectivity (logo), TE (logo) and TE Connectivity are trademarks of the TE Connectivity Ltd. family of companies. Crompton is a trademark of Crompton Parkinson and is used by TE Connectivity under a licence. Other logos, product and company names mentioned herein may be trademarks of their respective owners

TE Energy – innovative and economical solutions for the electrical power industry: cable accessories, connectors & fittings, insulators & insulation, surge arresters, switching equipment, street lighting, power measurement and control.

Tyco Electronics UK Ltd

TE Energy
Freebournes Road
Witham, Essex CM8 3AH
Phone: +44 (0)870 870 7500
Fax: +44 (0)870 240 5289
Email: Crompton.info@te.com
www.crompton-instruments.com

