



## **NX series RFID safety switches with lock**



# NX series RFID safety switches with lock

## Description



The safety switches of the NX series are the most compact on the market, making them the perfect solution for use in the smallest of spaces. These switches are used primarily on machines where the hazardous conditions remain for a while, even after the machines have been switched off; for example, mechanical parts such as pulleys, saw blades, etc., could continue to move, or parts of the machine could still be hot or under pressure. Thus, the switches can also be used if individual guards are only to be opened under certain conditions. Versions with mode 1 (safety outputs active when guard closed and locked) are interlocks with guard locking acc. to



ISO 14119; the product is labelled with the symbol shown.

## Bistable operating principle

The safety switch of the NX series is designed as bistable switch. This means that the internal solenoid that locks and unlocks the device does not operate in the normally de-energised or normally energized mode, but in the bistable mode, i.e., it is stably in the locked or unlocked position. The command for unlocking and unlocking continues to follow the "release on voltage" logic, i.e., as long as voltage is applied to the activation inputs of the solenoid, the actuator is unlocked. This approach offers numerous advantages, including, among others, the locked or unlocked state being retained even if the device should experience a power failure. Bistable operation of the internal solenoid ensures that the NX switch remains stably in the state to which it was last actuated.

## Maximum safety with a single device

### PL e + SIL 3

The NX series switches are constructed with redundant electronics. As a result, the maximum PL e and SIL 3 safety levels can still be achieved through the use of a single device on a guard. This avoids expensive wiring in the field and allows faster installation. Inside the control cabinet, the two electronic safety outputs must be connected to a safety module with OSSD inputs or to a safety PLC.

## Series connection of several switches

### PL e + SIL 3

One of the most important features of the NX series is the possibility of connecting up to 32 sensors in series, while still maintaining the maximum safety levels PL e laid down in EN ISO 13849-1 and SIL 3 acc. to EN IEC 62061. This connection type is permissible in safety systems which have a safety module at the end of the chain that monitors the outputs of the last NX switch. The fact that the PL e safety level can be maintained even with 32 sensors connected in series demonstrates the extremely secure structure of each single device.

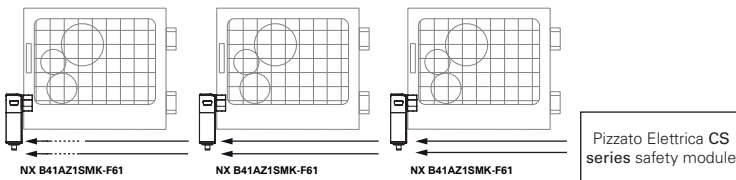

## Series connection with other devices

### PL e + SIL 3

The NX series features two safety inputs and two safety outputs, which can be connected in series with other Pizzato Elettrica safety devices. This option allows the creation of safety chains containing various devices. For example, stainless steel safety hinges (HX BEE1 series), transponder sensors (ST series) and door lock sensors (NX series) can be connected in series while still maintaining the maximum PL e and SIL 3 safety levels.



## RFID actuators with high coding level



The NX series is provided with an electronic system based on RFID technology to detect the actuator. This allows to provide each actuator with different coding and makes it impossible to tamper with a device by using another actuator of the same series. Millions of different coding combinations are possible for the actuators. They are therefore classified as high level coded actuators, according to EN ISO 14119.

## Holding force of the locked actuator

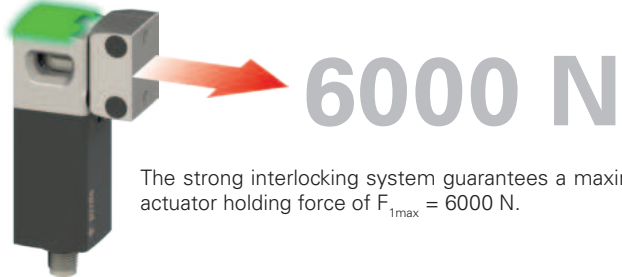

The strong interlocking system guarantees a maximum actuator holding force of  $F_{1max} = 6000 \text{ N}$ .

## Cover with multicolour signalling

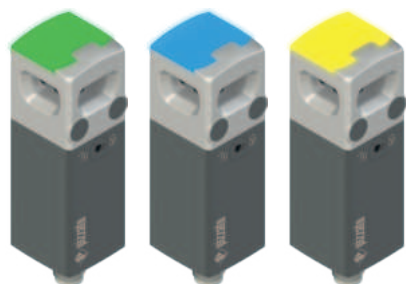

The switches of the NX series are the only switches in their market segment equipped with a large, illuminated RGB-LED cover that enables the fast and immediate diagnosis of the function states. As a result, this display can also easily be read from a distance and from all viewing angles.

## Metal head and technopolymer body



The housing of NX series switches is made of two materials:

- The metal head ensures maximum resistance to impacts from the actuator and resistance to pulling when the door is locked;
- The technopolymer body ensures a low weight and provides flexibility in the design.



### Three inputs for the actuators



The switch is always mounted using the two front screws, whereby it does not matter whether the doors open to the right or left or if they are sliding or hinged doors.

This is made possible by the three inputs for the actuator: one on the front and two on the sides. This eliminates the need to rotate the head or switch.

### Fixing the switch



loads from acting on the switch body.

The switch is fixed directly to the metal head with two M5 screws with a hole spacing of 20 mm. The arrangement of the fixing points near the actuator's point of traction allows the loads to be distributed on a robust and compact metal structure. This ensures that the switch can withstand considerable mechanical loads without being damaged or deformed in spite of its compact dimensions. Furthermore, this type of fixing prevents mechanical

### Holding force of the unlocked actuator



The inside of each switch features a device which holds the actuator in its closed position. Ideal for all those applications where several guards are unlocked simultaneously, but only one is actually opened. The device keeps all the unlocked guards in their position with a retaining force of approx. 15 N, stopping any vibrations or gusts of wind from opening them.

### Function for protecting against recoil forces

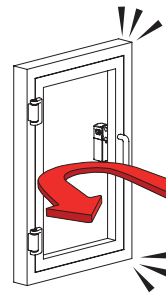

If a guard is closed too quickly or with so much force that the recoil would cause it to open again, a special function in the NX switch prevents locking. This function prevents the immediate locking of the guard if the lock signal is applied. This protects the switch against recoil forces that occur during instantaneous locking, thus avoiding possible damage to the device.

### Jointed actuator for inaccurately closing guards

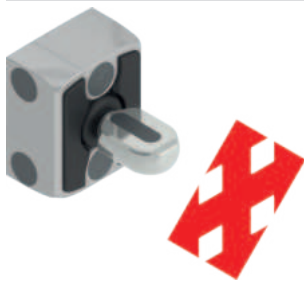

The actuator for the switches of the NX series is articulated, thereby allowing the actuator pin to be safely guided into the switch through the centring hole. As a result, the actuator and switch do not need to be precisely aligned during installation.

### Rotatable actuator



The actuator of the NX series switches is equipped with fastening holes for M5 screws on both the front and the sides. Moreover, the two half shells that make up the actuator housing can be opened and the pin turned so that the working plane of the actuator can be rotated by 90°.

### Guided insertion of the actuator

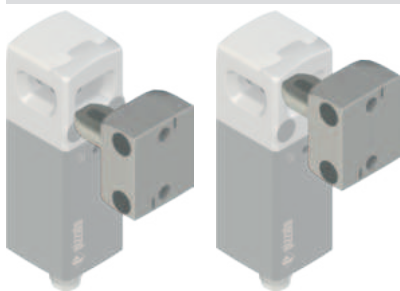

The actuator is always guided during insertion into the switch head. Any misalignments of the panels that arise during installation can thereby be corrected, thus ensuring precise and optimum positioning.

### Protection against tampering

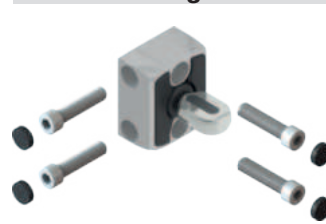

Each actuator of the NX series is supplied with snap-on protection caps. Not only do the caps prevent dirt from accumulating and simplify cleaning, they also block access to the fastening screws of the actuator. As a result, standard screws can be used instead of tamper-proof screws.

### Two safety output actuation modes

**MODE 1**  
**MODE 2**

The device is available with 2 different actuation modes for safety outputs:

- Mode 1: safety outputs active with inserted and locked actuator, for machines with inertia;
- Mode 2: safety outputs active with inserted actuator, for machines without inertia.

### High protection degree

**IP69K**  
**IP67**

These devices are designed to be used in the toughest environmental conditions and they pass the IP67 immersion test acc. to EN 60529. They can therefore be used in all environments where the maximum degree of protection is required for the housing. Due to their special design, these devices are suitable for use in equipment subjected to cleaning with high pressure hot water jets. These devices meet the IP69K test requirements according to ISO 20653 (water jets with 100 bar and 80°C).

### External device monitoring

**EDM**

On request, the switch can be supplied with EDM function (External Device Monitoring). In this case, the switch itself checks the proper function of the devices connected to the safety outputs. These devices (usually relays or safety contactors) must send a feedback signal to the EDM input, which checks that the received signal is consistent with the state of the safety outputs.

## Selection diagram

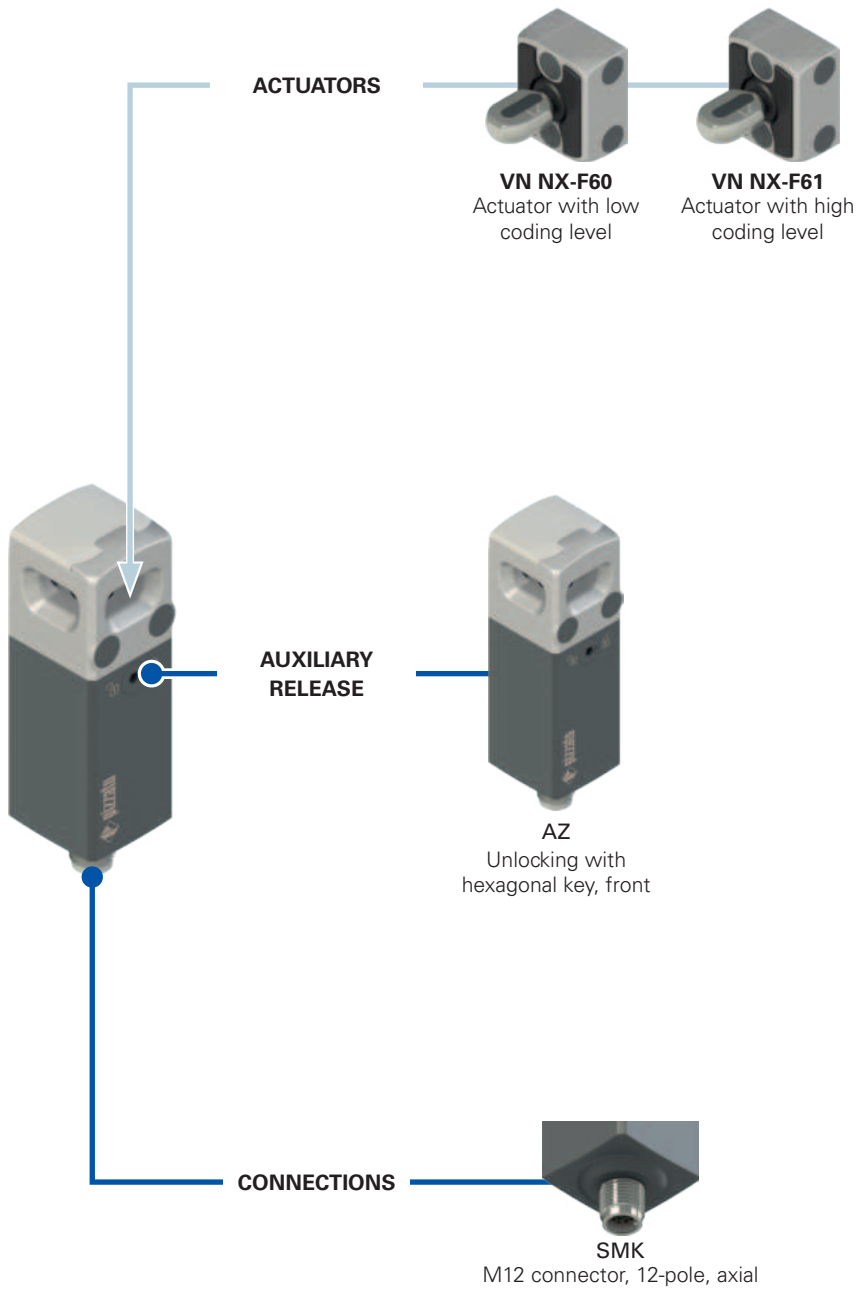

- product option
- Product sold separately



## Code structure

**Attention!** The feasibility of a code number does not mean the effective availability of a product. Please contact our sales office.

# NX B42AZ1SMK-F61

article

options

### Type of operation and activation mode of the safety outputs

<b>B</b>	Mode 1 of bistable solenoid. Activation of OS1 and OS2 with inserted and locked actuator.
<b>P</b>	Mode 2 of bistable solenoid. Activation of OS1 and OS2 with inserted actuator.

Actuator	
<b>F60</b>	Actuator with low coding level VN NX-F60 the switch recognises any type F60 actuator
<b>F61</b>	Actuator with high coding level VN NX-F61 the switch recognises one single type F61 actuator

Type of integrated cable or connector	
<b>SMK</b>	M12 connector, 12-pole, axial

Inputs and outputs	
<b>3</b>	2 safety inputs IS1, IS2 2 safety outputs OS1, OS2 1 signalling output O3: actuator inserted 1 signalling output O4: actuator locked 2 inputs for solenoid activation IE1, IE2 1 reset input I3
<b>4</b>	2 safety inputs IS1, IS2 2 safety outputs OS1, OS2 1 signalling output O3: actuator inserted 1 signalling output O4: actuator locked 2 inputs for solenoid activation IE1, IE2 1 programming / reset input I3
<b>5</b>	2 safety inputs IS1, IS2 2 safety outputs OS1, OS2 1 signalling output O3: actuator inserted 1 signalling output O4: actuator locked 2 inputs for solenoid activation IE1, IE2 1 programming / reset input I3 1 feedback input EDM I5

Auxiliary release	
<b>AZ</b>	Unlocking with hexagonal key, front

Actuator recognition	
<b>1</b>	Actuator pre-programmed in the factory (Supplied only together with actuator)
<b>2</b>	Reprogrammable actuator (not available for articles NX ●3●●●●●●)

## Code structure for actuator

# VN NX-F60

Actuator	
<b>F60</b>	actuator with low coding level the switch recognises any type F60 actuator
<b>F61</b>	actuator with high coding level the switch recognises one single type F61 actuator



## Main features

- Actuation without contact, using RFID technology
- Bistable operating principle
- Cover with multicolour signalling
- Digitally coded actuator
- SIL 3 and PL e also with series connection of up to 32 devices
- Max. actuator holding force when locked: 6000 N
- SIL 3 and PL e with a single device
- Uniform fixing, independent of door type
- Protection degrees IP67 and IP69K

## Quality marks:



EC type examination certificate: Pending  
 UL approval: Pending  
 TÜV SÜD approval: Pending

## In compliance with standards:

EN ISO 14119, EN 60947-5-3, EN IEC 60947-1, EN 60204-1, EN ISO 12100, EN 60529, EN 61000-6-2, EN 61000-6-3, EN 61508-1, EN 61508-2, EN 61508-3, EN ISO 13849-1, EN ISO 13849-2, EN IEC 62061, EN IEC 61326-1, EN 61326-3-1, EN IEC 63000, ETSI EN 301 489-1, ETSI EN 301 489-3, ETSI EN 300 330-2, UL 508, CSA 22.2 No.14

## Compliance with the requirements of:

Machinery Directive 2006/42/EC, EMC Directive 2014/30/EC, RED Directive 2014/53/EU, RoHS directive 2011/65/EU, FCC Part 15.

## Technical data

Metal head, glass fibre reinforced technopolymer, self-extinguishing and shock-proof.

Integrated M12 stainless steel male connector

Protection degree: IP67 acc. to EN 60529

IP69K acc. to ISO 20653 (Protect the cables from direct high-pressure and high-temperature jets)

## General data

Safety parameters	Maximum SIL	PL	Cat.	DC	PFH <sub>o</sub>	MTTF <sub>o</sub>
Monitoring function: actuator locked - Mode 1	3	e	4	High	3,07E-10	1688
Monitoring function: actuator present - Mode 2	3	e	4	High	3,07E-10	1694
Dual-channel control for locking function of the actuator	3	e	4	High	2,82E-10	1639
Single-channel control for locking function of the actuator	2	d	2	High	2,82E-10	1639

Interlock with lock, no contact, coded: type 4 acc. to EN ISO 14119  
 Coding level acc. to EN ISO 14119: Low with F60 actuator  
 High with F61 actuator

Ambient temperature: -20°C ... +50°C

Max. actuation frequency with actuator lock and release: 600 operating cycles/hour  
 Mechanical endurance: 1 million operating cycles

Max. actuation speed: 0.5 m/s

Min. actuation speed: 1 mm/s

Maximum force before breakage  $F_{1max}$ : 6000 N acc. to EN ISO 14119

Max. holding force  $F_{Zh}$ : 3000 N acc. to EN ISO 14119

Maximum clearance of locked actuator: 2 mm

Released actuator extraction force: ~ 15 N

## Electrical data

Rated operating voltage  $U_e$  SELV: 24 Vdc  $\pm 10\%$

Operating current at  $U_e$  voltage: 60 mA min;  
 0.45 A max. upon solenoid activation;  
 0.8 A with all outputs at maximum power  
 32 Vdc

Rated insulation voltage  $U_i$ : III

Overvoltage category: III

Electrical endurance: 1 million operating cycles

Solenoid duty cycle: 100% ED (continuous operation)

Power consumption of the solenoid during transitions from locked to unlocked: 10 W

## Electrical data of inputs IS1/IS2/I3/IE1/IE2/I5/EDM

Rated operating voltage  $U_{e1}$ : 24 Vdc

Rated current consumption  $I_{e1}$ : 5 mA

## Electrical data of OS1/OS2 safety outputs

Rated operating voltage  $U_{e2}$ : 24 Vdc

Output type: PNP type OSSD

Maximum current per output  $I_{e2}$ : 0.25 A

Minimum current per output  $I_{m2}$ : 0.5 mA

Thermal current  $I_{th2}$ : 0.25 A

Utilization category: DC13;  $U_{e2}=24$  Vdc,  $I_{e2}=0.25$  A

Short circuit detection: Yes

Overcurrent protection: Yes

Activation time of safety outputs OS1 and OS2 after deactivation of inputs: typically 10 ms, max. 15 ms

Response time upon unlocking the actuator: typically 15 ms, max. 20 ms

Response time upon removal of the actuator: typically 60 ms, max. 200 ms

Maximum delay for EDM status change: 500 ms

## Electrical data of O3/O4 signalling outputs

Rated operating voltage  $U_{e3}$ : 24 Vdc

Output type: PNP

Maximum current per output  $I_{e3}$ : 0.1 A

Utilization category: DC13;  $U_{e3}=24$  Vdc,  $I_{e3}=0.1$  A

Overcurrent protection: Yes

## RFID sensor data

Assured operating distance  $S_{ao}$ : 1 mm

Assured release distance  $S_{ar}$ : 10 mm (actuator not locked)  
 12 mm (actuator locked)

Rated operating distance  $S_n$ : 2.5 mm

Repeat accuracy:  $\leq 10\%$   $s_n$

RFID transponder frequency: 125 kHz

Max. switching frequency: 1 Hz





## Actuation mode of the OS1 and OS2 safety outputs

### Mode 1

Safety outputs OS1 and OS2 are active when the actuator is inserted and locked.

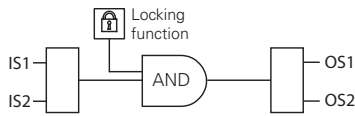

In case of machines with or without inertia of the dangerous elements. Safety category of the safety outputs: PL e, SIL 3.

### Mode 2

Safety outputs OS1 and OS2 are active when the actuator is inserted.

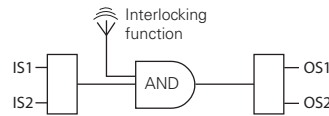

In case of machines without inertia of the dangerous elements. Safety category of the safety outputs: PL e, SIL 3.

## Selection table for switches with actuator with high coding level

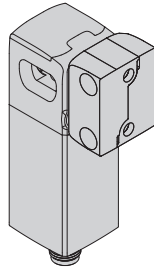
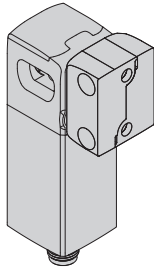

Operating principle	Bistable	Bistable With EDM input
Mode 1	NX B42AZ1SMK-F61	NX B52AZ1SMK-F61
Mode 2	NX P42AZ1SMK-F61	NX P52AZ1SMK-F61

## Selection table for switches

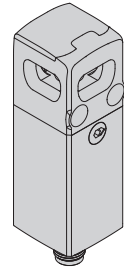
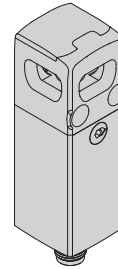

Operating principle	Bistable	Bistable With EDM input
Mode 1	NX B42AZ1SMK	NX B52AZ1SMK
Mode 2	NX P42AZ1SMK	NX P52AZ1SMK

## Selection table for actuators

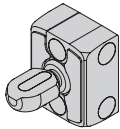

Type F60 actuators are all encoded with the same code. This implies that a device associated with an actuator type F60 can be activated by other actuators type F60.

Type F61 actuators are always encoded with different codes. This implies that a device associated with an actuator type F61 can be activated only by a specific actuator. Another F61 type actuator will not be recognised by the device until a new association procedure is carried out (reprogramming). After reprogramming, the old actuator F61 will no longer be recognized.

Reprogramming of the actuator can be performed repeatedly.

Coding level acc. to EN ISO 14119	Article
low	VN NX-F60
high	VN NX-F61

## Dimensional drawings

Device  
NX ••2AZ1SMK

Actuator  
VN NX-F6•

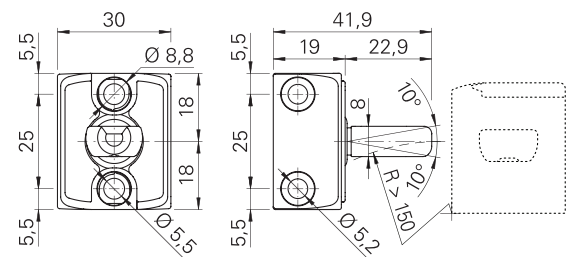
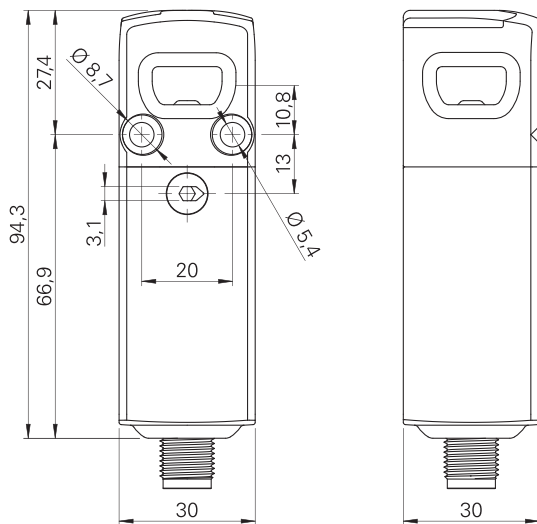



### Output type

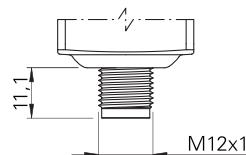





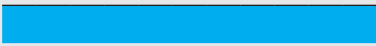

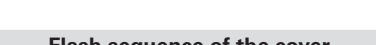



M12 connector, axial

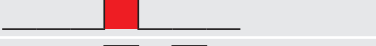

# NX series RFID safety switches with lock

## Operating states

Illumination of the cover	Device state	Description
	OFF	Device switched off.
	RUN	Actuator in safe area and locked. O3 and O4 signalling outputs active. In mode 1: with activation of the IS1 and IS2 safety inputs, the OS1 and OS2 safety outputs are activated.
	RUN	Actuator in safe area. O3 signalling output active. In mode 2: with activation of the IS1 and IS2 safety inputs, the OS1 and OS2 safety outputs are activated.
	RUN	Actuator outside of the activation zone.
	RUN	Actuator programming.
	ERROR	Internal error. Recommended action: restart the device. If the failure persists, replace the device.

Flash sequence of the cover	Device state	Description
	ERROR	Temperature error: The temperature of the device is outside of the permissible range.
	ERROR	Voltage error: the device supply voltage is outside permitted limits.
	ERROR	Error on safety outputs. Recommended action: check for any short circuits between the outputs, outputs and ground or outputs and power supply, then restart the device.
	ERROR	Actuator detection error. Recommended action: check the physical integrity of the device and, in case of failure, replace the entire device. If undamaged, realign the actuator with the device and restart the device.
	ERROR	Error in the EDM <sup>(1)</sup> function
	WARNING	Warning: auxiliary release activated. Deactivate the auxiliary release to lock the actuator
	WARNING	Temperature warning: the device temperature is close to permitted limits.
	WARNING	Warning: movement of the solenoid pin is impeded or the solenoid is overheated
	WARNING	Voltage warning: the device supply voltage is close to permitted limits.
	WARNING	OSSD current warning: the current on the safety outputs is close to the permissible limit values.
	WARNING	Warning: no signal present at the safety inputs.
	WARNING	Warning: signals at the safety inputs inconsistent. Recommended action: check for presence and/or wiring of inputs.
	WARNING	Warning: inputs of the solenoids inconsistent. Recommended action: check for presence and/or wiring of inputs.
	SET	TAG programming finished

<sup>(1)</sup> Only available in the NX •5••••• versions

## Actuation sequence in mode 1

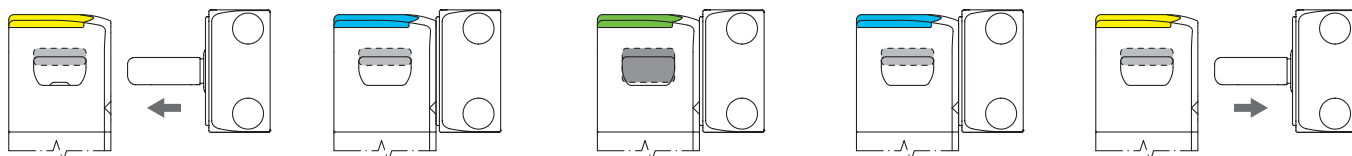

The switch is supplied with power, the IS1 and IS2 inputs are enabled, the OS1 and OS2 safety outputs are disabled. The actuator is outside of the actuation zone (cover illuminates yellow).

If the actuator is brought inside the safe actuation zone (dark grey area), the cover illuminates light blue. In this position, the O3 signalling output (door-closed) is activated. The actuator is not locked.

The IE1 and IE2 inputs can be used to lock the actuator and the cover illuminates green. The OS1 and OS2 safety outputs are enabled. The O4 signalling output is activated at the same time. The safe actuation area is extended in order to allow greater play for the actuator.

The IE1 and IE2 inputs can be used to unlock the actuator (the cover illuminates light blue). The switch disables the OS1 and OS2 safety outputs. The O4 signalling output is deactivated at the same time. The safe actuation area returns to the initial values.

As soon as the actuator leaves the actuation zone, the device deactivates the O3 signalling output and the cover illuminates yellow.

## Actuation sequence in mode 2

In contrast to the above mode 2 description, the safety outputs OS1 and OS2 enable when the actuator is detected, and disable when the actuator is no longer detectable.





## Complete safety system

The use of complete and tested solutions guarantees the electrical compatibility between the NX series switches and the safety modules from Pizzato Elettrica, as well as high reliability. The switches have been tested with the modules listed in the adjacent table.

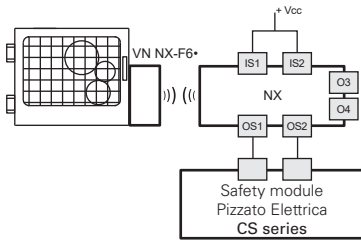

NX series switches can be used as individual devices provided that the safety outputs be evaluated by a Pizzato Elettrica safety module (see table for combinable safety modules).

Switches	Compatible safety modules	Safety module output contacts		
		Instantaneous safety contacts	Delayed safety contacts	Signalling contacts
NX ●●●●1●●●	CS AR-05●024	3NO	/	1NC
	CS AR-06●024	3NO	/	1NC
	CS AR-08●024	2NO	/	/
	CS AT-0●●024	2NO	2NO	1NC
	CS AT-1●●024	3NO	2NO	/
	CS MP●●●●●●	page 309 of the General Catalogue Safety		
	CS MF●●●●●●	page 341 of the General Catalogue Safety		

All NX series switches can be connected, provided that compatibility is checked, to safety modules or safety PLCs with OSSD inputs.

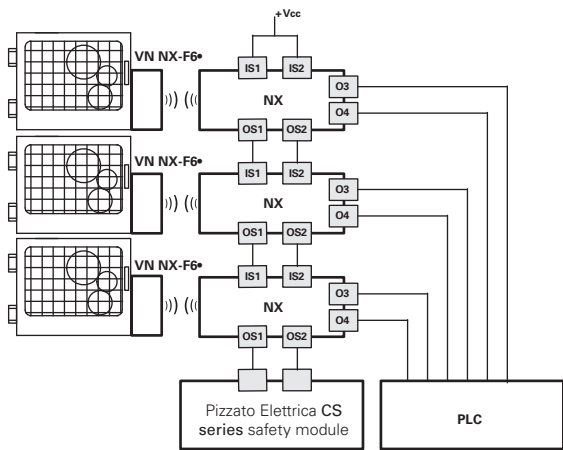

Possibility of series connection of multiple switches for simplifying the wiring of the safety system, whereby only the outputs of the last switch are evaluated by a Pizzato Elettrica safety module (see table with compatible safety modules). Each NX series switch is provided with two signalling outputs which are activated when the guard is closed (O3) or locked (O4). Depending on the specific requirements of the system that has been realised, the signals of the signalling outputs can be evaluated by a PLC.

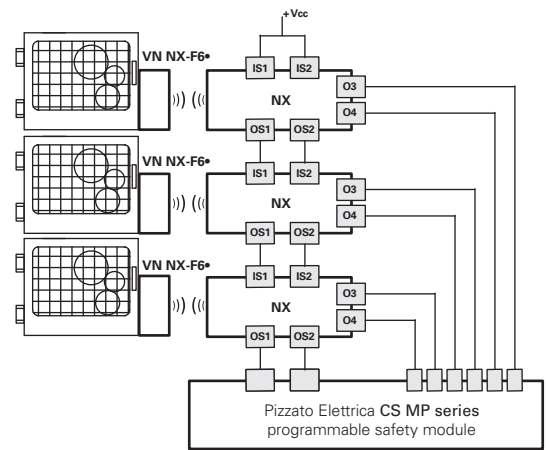

Possibility of series connection of multiple switches for simplifying the wiring of the safety system, whereby only the outputs of the last switch are evaluated by a Pizzato Elettrica safety module of the CS MP series. Both the safety-relevant evaluation and the evaluation of the signalling outputs are performed by the CS MP series.

The examples listed above refer to applications with NX ●●●●1●●●.

## Internal wiring diagram

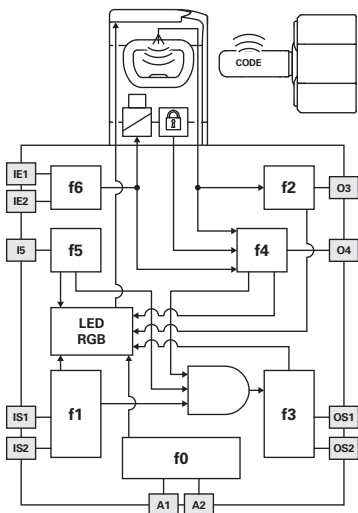

The diagram on the side represents the 7 logic functions which interact inside the device.

Function f0 is a basic function and includes the monitoring of the power supply as well as internal, cyclical tests. Function f1 monitors the status of the device inputs, whereas function f2 monitors the presence of the actuator within the detection areas of the switch.

Function f4 checks the actuator lock condition.

Function f3 is intended to activate or deactivate the safety outputs and check for any faults or short circuits in the outputs.

In the EDM versions, the f5 function verifies the consistency of the EDM signal during safety output state changes.

The safety-related function, which combines the sub-functions mentioned above, activates the safety outputs according to the chosen operating mode:

- Both safety outputs OS1/OS2 for switches in mode 1 are activated only if both IS1/IS2 safety inputs are active and the actuator is inserted and locked;
- Both safety outputs OS1/OS2 for switches in mode 2 are activated only if both IS1/IS2 safety inputs are active and the actuator is inserted;

The f6 function verifies the coherence of the enable/disable signals of the actuator lock command.

## External device monitoring (EDM)

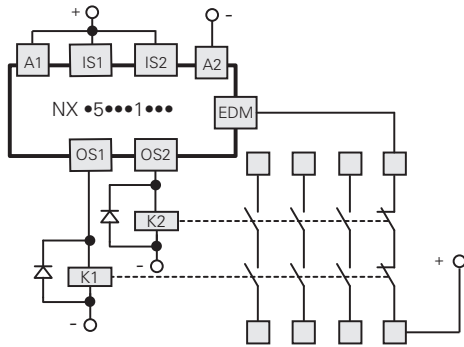

The NX •5•••1••• version, in addition to maintaining the operating and safety characteristics of the NX series, allows control of **forcibly guided NC contacts of contactors or relays** controlled by the safety outputs of the switch itself. As an alternative to the relays or contactors you can use Pizzato Elettrica expansion modules CS ME-03 (see page 267). This check is carried out via the EDM input (External Device Monitoring as defined in EN 61496-1) of the switch.

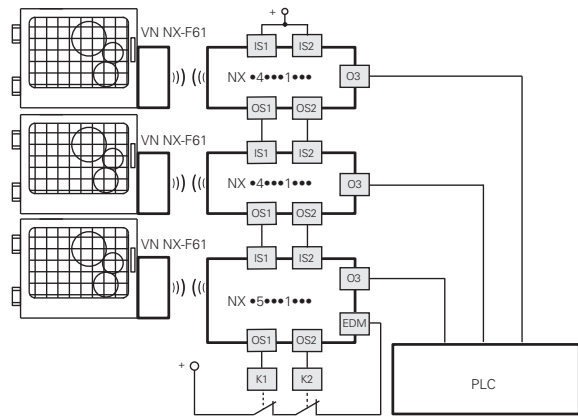

This version, with the IS safety inputs, **can be used at the end of a series of NX switches, up to a maximum number of 32 devices**, while maintaining the maximum PL e safety level and acc. to EN ISO 13849-1 and SIL 3 safety level acc. to EN IEC 62061. This solution allows you to dispense with the safety module connected to the last device in the chain. If present, the EDM function must be used.

## Connection with safety modules

Connections with CS AR-08•••• safety modules

Input configuration with monitored start

2 channels / Category 4 / up to SIL 3 / PL e

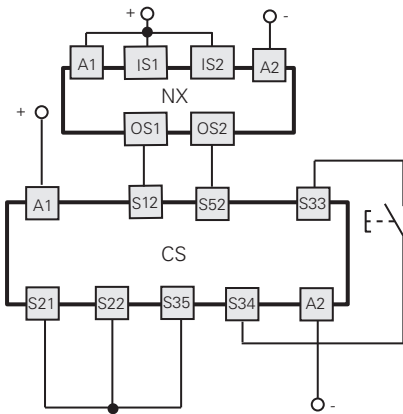

Connections with CS AR-05•••• / CS AR-06•••• safety modules

Input configuration with manual start (CS AR-05••••) or monitored start (CS AR-06••••)

2 channels / Category 4 / up to SIL 3 / PL e

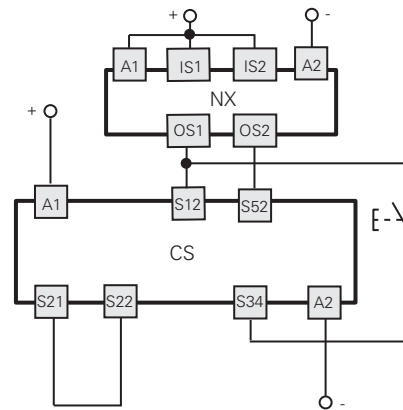

Connections with CS AT-0••••• / CS AT-1••••• safety modules

Input configuration with monitored start

2 channels / Category 4 / up to SIL 3 / PL e

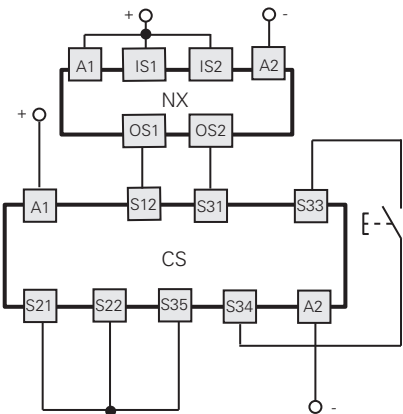

Connections with CS MF•••••, CS MP••••• safety modules

The connections vary according to the program of the module

Category 4 / up to SIL 3 / PL e

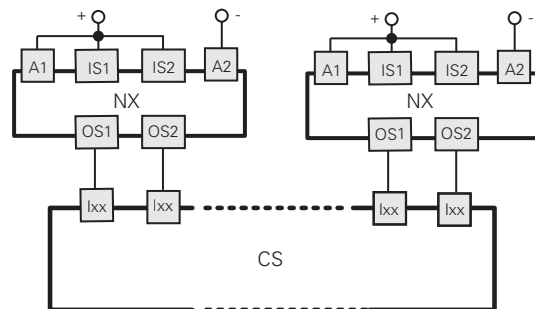

Application example on page 307, General Catalogue Safety 2023-2024



## Series connection of several switches

Monitoring function: actuator locked  
2 channels / Category 4 / up to SIL 3 / PL e

Single-channel control for locking function of the actuator  
1 channel / Category 2 / up to SIL 2 / PL d

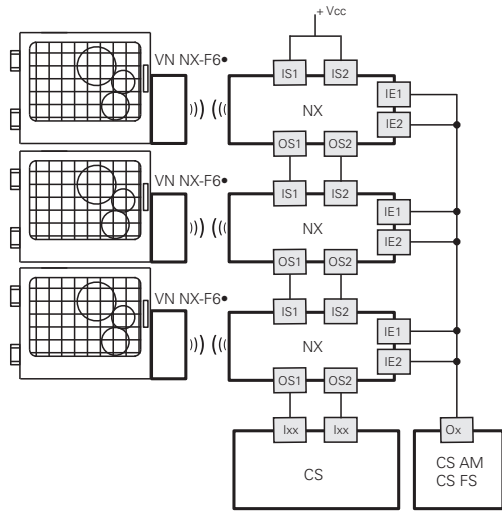

Monitoring function: actuator locked  
2 channels / Category 4 / up to SIL 3 / PL e

Dual-channel control for locking function of the actuator  
2 channels / Category 4 / up to SIL 3 / PL e

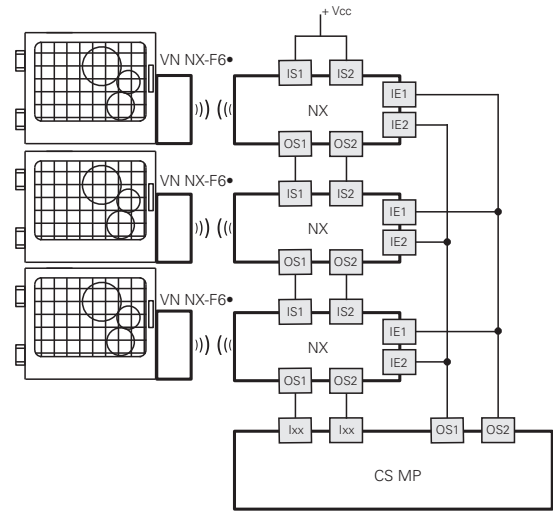

## Safety switch internal connections

NX •••••SMK M12 connector, 12-pole	Connection
3	A2 Supply input 0 V
10	IE1 Solenoid activation input
12	IE2 Solenoid activation input
5	O3 Signalling output, actuator inserted
9	O4 Signalling output, actuator inserted and locked
8	I3 Actuator programming input / reset
1	A1 Supply input +24 Vdc
2	IS1 Safety input
6	IS2 Safety input
11	I5 EDM input (a)
4	OS1 Safety output
7	OS2 Safety output

(a) Only available in version NX •5•••••

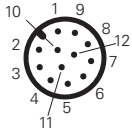



General Catalogue  
Detection

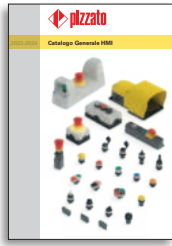

General Catalogue  
HMI



General Catalogue  
Safety

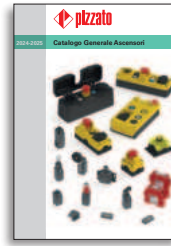

General Catalogue  
Lift



Website  
[www.pizzato.com](http://www.pizzato.com)



**Pizzato Elettrica s.r.l.** via Torino, 1 - 36063 Marostica (VI) Italy  
Phone: +39 0424 470 930  
E-mail: [info@pizzato.com](mailto:info@pizzato.com)  
Website: [www.pizzato.com](http://www.pizzato.com)

Any information or application example, connection diagrams included, described in this document are to be intended as purely descriptive. The choice and application of the products in conformity with the standards, in order to avoid damage to persons or goods, is the user's responsibility. The drawings and data contained in this document are not binding and we reserve the right, in order to improve the quality of our products, to modify them at any time without prior notice. All rights to the contents of this publication are reserved in accordance with current legislation on the protection of intellectual property. The reproduction, publication, distribution and modification, total or partial, of all or part of the original material contained therein (including, but not limited to, texts, images, graphics), whether on paper or in electronic form, are expressly prohibited without written permission from Pizzato Elettrica Srl. All rights reserved. © 2024 Copyright Pizzato Elettrica

ZE FGL36A24-ENG

