

RM-8WAY-24VAC RELAY MODULE



RM-8WAY-24VAC Relay Module

The relay module provides 8 relays, either mechanical 46.61-024-DC relays or SSR-EDxxC5 solid state relays. The relay module can be populated with a mixture of mechanical relays and solid state relays to suit the loads being switched.

Relay control is via terminals using an external 24V AC or DC supply.

Order code:

RM-8WAY-24VAC 8 way relay module.
Fitted with 46.61-024V-DC relays

Specifications

Outputs	8 relays with fuse holders Either 46.61-024-DC mechanical relays or SSR-EDxxC5 solid state relays * NOTE fuses not supplied with the unit 46.61-024-DC relays : 250VAC 10A CO (fuse/fuse holder limited) SSR-ED06C5 relays : 1-48Vdc 5A NO SSR-ED24C5 relays : 24-280Vac 5A NO
Relay Control	: 8x 24V AC or DC via terminals : approx. 30mA per relay at 24Vac, 27mA per relay at 24Vdc : operating range 18V to 28V, AC or DC
Temperature	Operating : -10°C to +60°C Storage : -20°C to +70°C
EMC Compliance	: AS/NZS 61000.6.3:2012
Housing	DIN rail mounted polyamide, flame retardant UL 94 V0.
Terminals	Spring steel clamp, tin plated copper alloy terminal : up to 1.5mm ² stranded conductor : wire stripping 9mm

Relay Output Configuration Mechanical Relays or Solid State Relays

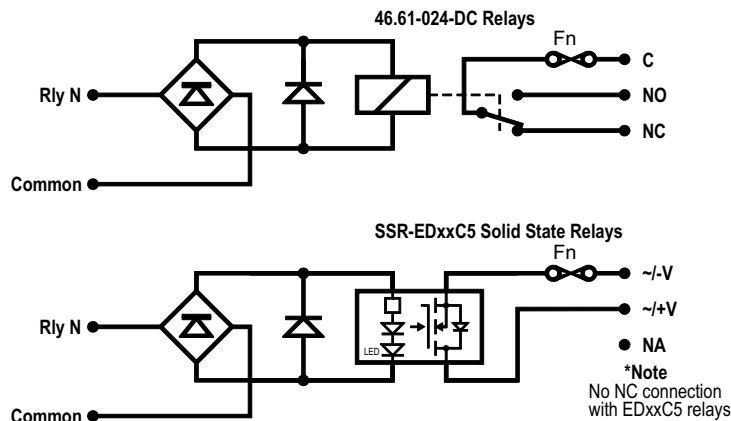

CARREL ELECTRADE LTD

MANUFACTURERS, IMPORTERS AND DISTRIBUTORS OF ELECTRICAL ENGINEERING PRODUCTS
POSTAL ADDRESS: P O BOX 11078, ELLERSLIE 1542, AUCKLAND NEW ZEALAND
FACTORY AND OFFICE: 661 GREAT SOUTH ROAD, PENROSE 1061
TELEPHONE: +64-9-525 1753 FACSIMILE: +64-9-525 1756
CHRISTCHURCH BRANCH: 73B BRISBANE STREET, SYDENHAM
TELEPHONE: 03-366 1242 FACSIMILE: 03-379 1991
EMAIL: sales@ carrel-electrade.co.nz WEB: www.carrel-electrade.co.nz

RM-8WAY-24VAC RELAY MODULE

Dimensions

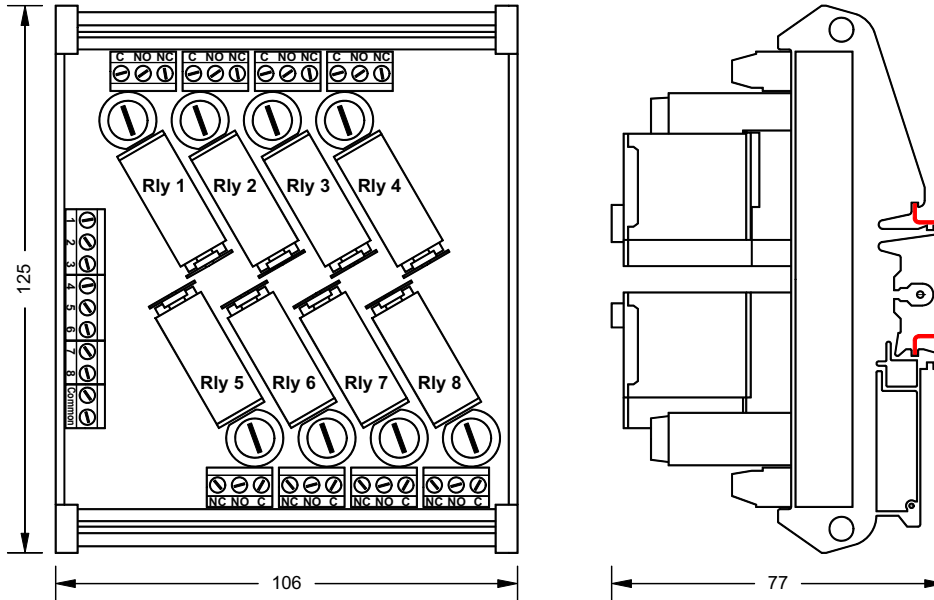

Circuit Diagram

