



~ ACUREV 1310 ~

THREE-PHASE DIN-RAIL MULTIFUNCTION METER

AN ACCUEVERGY SOLUTION

PRODUCT OVERVIEW

The AcuRev 1310 DIN Rail meter combines high performance with ease of integration to provide a cost-effective power and energy monitoring solution. Featuring a built-in LCD display designed to simplify setup and local reading of meter data. While the Modbus-RTU and pulse output communication allows seamless integration with data acquisition systems.

KEY FEATURES

The AcuRev 1310 Series of three-phase multi-circuit power and energy meters offer revenue grade accuracy and a wealth of other features, including:

- Utility Revenue Grade Accuracy - IEC 62053-22 0.5s Class / ANSI C12.20 0.5 Class
- Multiple CT Input Options compatible with any CT: 5A/1A, 333mV, Flexible Rogowski Coil, 80/100/200mA
- 4 Channel current input including neutral current measurement
- Residual current measurement available
- 10-690Vac direct voltage input, fits all voltage rating system with one model
- RS-485 port built-in with Modbus-RTU, standard integration with most systems
- Standard Din-rail mount for ease-of-installation
- Compatible with both 50Hz and 60Hz systems
- Built-in energy pulse output and alarm output
- Optional relay output for alarm and remote control
- Tamper-proof design approved for revenue applications

UNIVERSAL RATING

Voltage: Measuring from 10V to 400VL-N 690VL-L that works with most voltage ratings without a Potential Transformer. Potential transformer ratio configuration supported for high voltage systems where PT is used.

Frequency: Automatically adapt to 50Hz and 60Hz system without compromising the accuracy, which simplifies design and eliminates international OEM frequency issues.

ADDITIONAL FEATURES

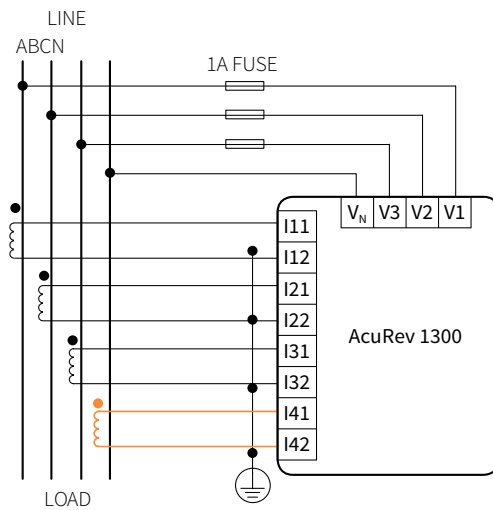

FOUR CHANNEL CT INPUT

Accurately measure neutral current with 4th CT and provide residual current measurement.

AUTO PHASE-CHECK

Designed to automatically check most common wiring mistakes such as CT direction, voltage and current phase alignment.

SUPPORTS ALL ELECTRICAL SYSTEM CONFIGURATIONS

Three phase three wire (3P3W), three phase four wire (3P4W), single phase three wire (1P3W two element), single phase two wire (1P2W one element) and more.

ACUREV 1310 FUNCTIONS

Feature	1311	1312	1313	1314
Bi-Directional Energy Measurement			●	●
Active Energy	●	●	●	●
Reactive Energy		●	●	●
Apparent Energy		●	●	●
Time-of-Use		●	●	●
Power Demand		●	●	●
Peak Power Demand		●	●	●
Predictive Demand (existing in AcuRev 2000)		●	●	●
Current Demand		●	●	●
Peak Current Demand		●	●	●
Voltage	●	●	●	●
Current	●	●	●	●
Neutral Current	Calculated	Calculated	Calculated	●
Residual Current				Calculated
Active Power	●	●	●	●
Reactive Power		●	●	●
Apparent Power		●	●	●
Power Factor		●	●	●
Frequency		●	●	●
Clock		●	●	●
Running Time	●	●	●	●
Energy Pulse Output	●	●	●	●
Relay Output (Alarm or Control)		●	●	●
RS485 Modbus-RTU		●	●	●
Wiring Check	●	●	●	●
Temperature	●	●	●	●
SunSpec	●	●	●	●
Current Transformer (CT) Input	5A / 1A: Field-Configurable CT Input 333mV: CT Input RCT: Flexible Rogowski Coil CT Input 80/100/200mA: Field-Configurable CT Input			
I/O Options:	One relay output for alarm and remote control			

METERING

Parameter	Accuracy	Resolution	Range
Active Energy	0.5%	1Wh	0-999999999
Reactive Energy	0.5%	1varh	0-999999999
Apparent Energy	0.5%	1VAh	0-999999999
Voltage	0.5%	0.1	10V-1000KV
Current	0.5%	0.001A	10mA-500000A
Active Power	0.5%	1W	-99-99MW
Reactive Power	0.5%	1var	-99-99Mvar
Apparent Power	0.5%	1VA	-99-99MVA
Power Factor	0.5%	0.001	-1.000-1.000
Frequency	0.2%	0.01Hz	50/60
Power Demand	0.5%	1W/var/VA	99MW/Mvar/MVA
Current Demand	0.5%	0.001A	10mA-5000A

SPECIFICATIONS

Voltage	
Rated Voltage	400Vac L-N 690Vac L-L
Input Impedance	2M Ω /Phase
Measurement Frequency	50/60Hz
Accuracy	0.5%
Current Input	
Stated Current (IN)	5Aac/1Aac
Start Current	10mA
Accuracy	0.5%
Pulse Output	
Isolation Voltage	2500Vac
Load Voltage	0-250Vac
Load Current	100mA (max)
Power Supply	
Working Power Supply	100-415Vac, 50/60Hz, 100-300Vdc
Power Consumption	<2W or 10VA

Relay Output	
Load Voltage	250Vac 30Vdc
Max Load Current	5A(Resistant Load)
Isolation Voltage	2000Vac(1min)
Action Time	10ms
Mechanical Life	20 million times
Electrical Life	Above 50,000 Times (5A, 250Vac, Resistant Load)
Communication	
RS485 Baud Rate	1200-34800
Communication Protocol	Modbus-RTU
Infrared Communication	2000Vac(1min)
Infrared Baud Rate	10ms
Environment	
Working Temperature	-25-70°C
Storage Temperature	-40-85°C

TYPICAL WIRING

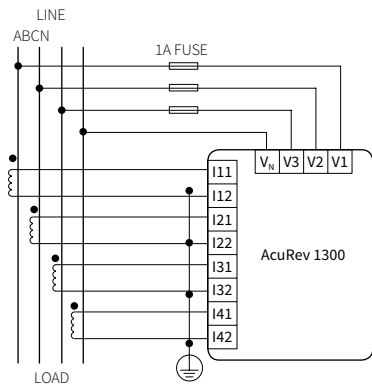

3LN, 3CT

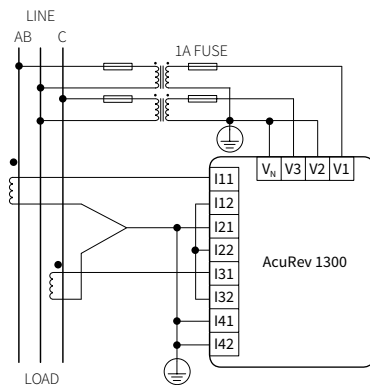

3LL, 3CT

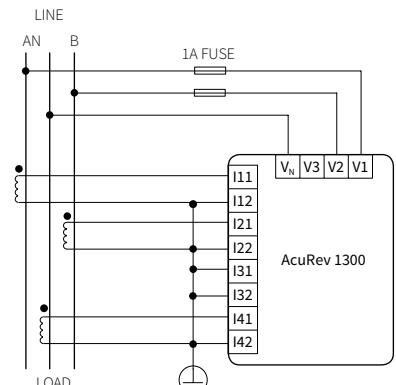

1LL, 2CT

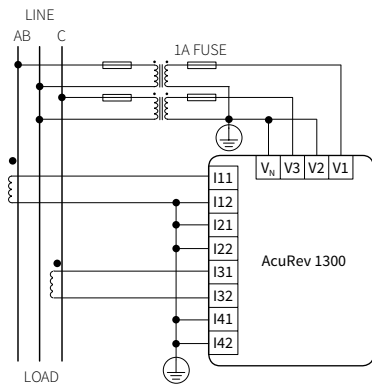

2LL, 2CT

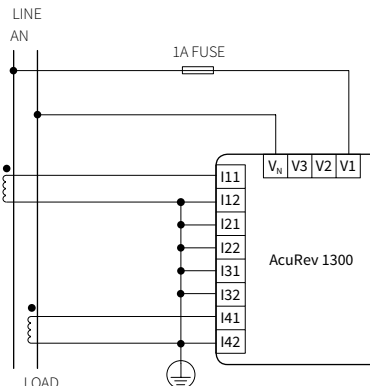

1LN, 1CT

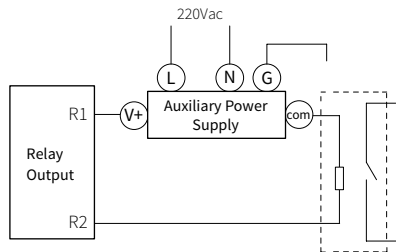

Relay output

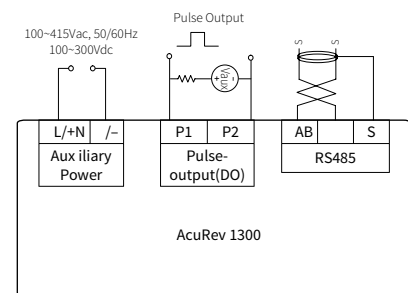

Auxiliary Power + Pulse + RS485

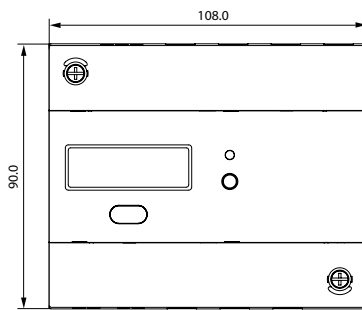

Dimensions

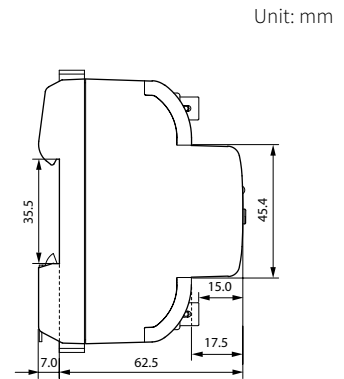

Unit: mm

ORDERING INFORMATION

	Model	Current Input	I/O
ORDERING NUMBER	-	-	-
ORDERING EXAMPLE	AcuRev 1313	333	X1
	AcuRev 1311	5A: Field configurable CT	X0: No Additional I/O
	AcuRev 1312	333: 333mV Input CT	X1: 1 Relay Output
	AcuRev 1313	RCT: Rogowski Coil CT	
	AcuRev 1314	mA: 80 / 100 / 200mA Input CT	

Please Note: AcuRev 1314 does not support Rogowski coil input for neutral current. Consult Accuenergy Engineering Support for correct configuration.

CURRENT TRANSFORMER OPTIONS



5A / 1A

Field-configurable CT input that suits any industrial and revenue-grade current transformer.



FLEXIBLE ROGOWSKI

Directly connect to Rogowski coil without integrator or power supply, ideal for any retrofit applications.



333mV

Compatible with any 333mV output current transformer for low cost energy efficiency and energy management systems.



80mA / 100mA / 200mA

Field-configuration to work with 80mA, 100mA and 200mA output CT that are used in revenue metering application.

Learn more about our Current Transformer options on Accuenergy.com



WWW.ACCUENERGY.COM

TF: 1-877-721-8908

INT: +1-416-497-4100

FAX: +1-416-497-4130

E: marketing@accuenergy.com

ACCUENERGY (CANADA) INC.

2 Lansing Square, Suite 1001

Toronto, ON M2J 4P8, Canada

NEED HELP?



CONTACT US FOR

ENGINEERING

DESIGN & SPECIFICATION SUPPORT



WWW.ACCUENERGY.COM