



AUTONICS MS86L LED BEACONS



Function	Steady + Flashing LED
Power Supply	24VAC/DC + 90-240VAC 50-60Hz
Outside Diameter	86mm
Flash Rate	80± 10 Flashes/min
Vibration	0.75mm @ 10-55Hz
Ambient Temperature	minus 20 + 40°C
Storage Temperature	minus 20-+70°C
Ambient Humidity	45-85%RH
Withstand Voltage	500VAC 50/60Hz for 1 min
Protection	IP65
Approval	UL-CE (24V only) - RoHS
Wire Size	UL2464/22AWGx2C
Weight	Approx 150g

Note: LED lifetime depends on operating and environmental conditions

Current Consumption (Maximum current consumption when LED is lit)		
Power Supply	24VAC/DC	90-240VAC
LED Colour	Current	
Red	0.33A	
Amber	0.46A	
Green	0.46A	0.05A
Blue	0.46A	
White	0.46A	

Codes:

- Amber low lens 24VAC/DC - **MS86L-F02-Y-F**
- Blue low lens 24VAC/DC - **MS86L-F02-B-F**
- Red low lens 24VAC/DC - **MS86L-F02-R-F**
- Amber low lens 90-240VAC - **MS86L-FFF-Y-F**
- Blue low lens 90-240VAC - **MS86L-FFF-B-F**
- Red low lens 90-240VAC - **MS86L-FFF-R-F**
- Amber high lens 24VAC/DC - **MS86L-F02-Y**
- Red high lens 24VAC/DC - **MS86L-F02-R**
- Amber high lens 90-240VAC - **MS86L-FFF-Y**
- Red high lens 90-240VAC - **MS86L-FFF-R**
- ABS resin bracket- **MAM-DS30**
- Steel bracket - **MAM-DS26**

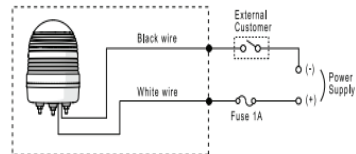
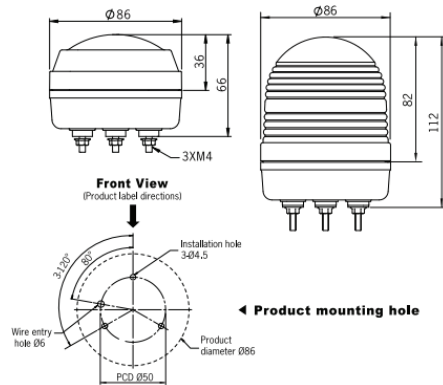

Well mounting Bracket

