

ASM Multi-tone alarm sounder

- 132 mm cubic-design multi-tone alarm sounder
- Max. 113 dB (A) sound pressure
- High degree of protection IP 66
- Optional mounting type using metal bracket
- 32 tones can be selected, 3 tones can be switched externally

- Sound pressure infinitely adjustable by potentiometer
- For industrial and general applications
- Combinations of multi-tone alarm sounders and beacons available

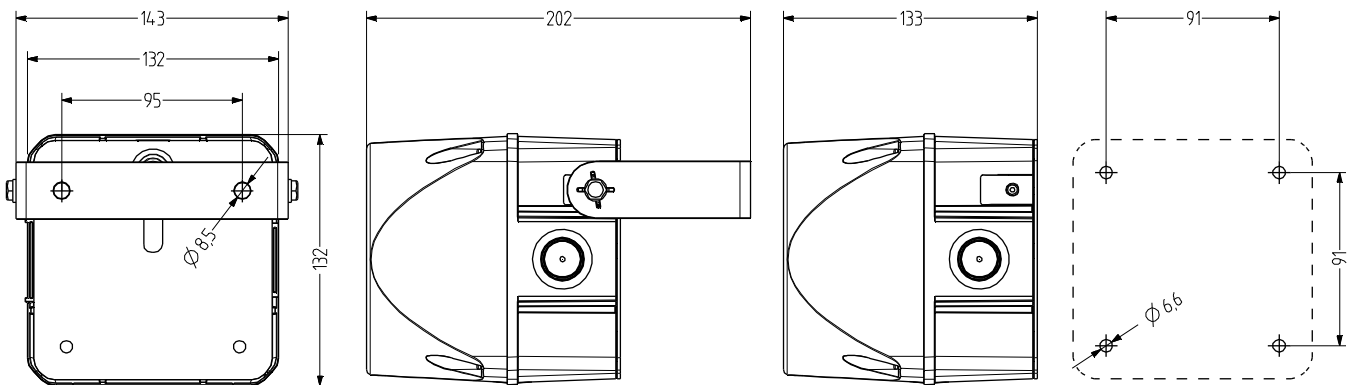

TECHNICAL DATA

Housing	Polycarbonate red (RAL 3000)
Type of mounting	any, Sound outlet opening at bottom or horizontal
Cable entry	Back: Grommet 5-10 mm Side: AKV cable gland M20 x 1.5 7-14 mm can be mounted
Connection technology	Screw/plug-in terminal up to 2,5 mm ²
Leakage current	0,003 A
Tone	32 Tones, 3 Tones can be switched externally, see tone table

Volume	113 dB (can be adjusted with potentiometer)
Tone frequency	150-2.900 Hz
Duty cycle	100 %
Operating temperature	-30 °C / +60 °C
Degree of protection	IP66 & UL Type 4/4x/13
Impact resistance	IK09
Weight	600 g

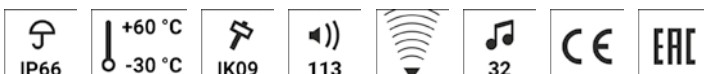

ASM

ORDER DATA

Nominal voltage	Voltage range (V)	Nominal current (A)	Mains frequency	Order number
24 V AC/DC	+/- 10 %	0,200	50-60 Hz	874 260 405
24-48 V AC/DC	21-53 V AC 21-60 V DC	0,200	50-60 Hz	874 260 408
120-240 V AC	80-265	0,075	50-60 Hz	874 260 313



AMK



AB2



AG2



AKV

ACCESSORIES

Type	Type of accessory	Weight	Order number
AMK	Mounting set for combining several pieces of signalling equipment of the same size	10 g	874 010 900
AB2	Mounting set for metal bracket for mounting in any direction (e.g. on mounting platforms)		874 032 900
AG2	Flat seal for correct IP66 installation on smooth surfaces		874 022 900
AKV	Cable gland M20x1,5		698 800 026

TONE TABLE

STAGE 1	Tone type	Frequency Hz	Pictogram	Repeat rate	Specific application	max dB	STAGE 2	STAGE 3
S1							S2	S3
Tone 01	continuous	660	—————		Swedish Alarm	108	Tone 16	Tone 12
Tone 02	continuous	1000	—————		PFEER toxic gas	109	Tone 16	Tone 25
Tone 03	continuous	2400	—————			113	Tone 21	Tone 17
Tone 04	intermittent	420	— — — —	0,625 s on / 0,625 s off	Australian alert AS1670	105	Tone 21	Tone 01
Tone 05	intermittent	660	— — — —	1,8 s on / 1,8 s off	Swedish Alarm	107	Tone 21	Tone 01
Tone 06	intermittent	660	— — — —	0,15 s on / 0,15 s off	Swedish Alarm	107	Tone 16	Tone 01
Tone 07	intermittent	970	— — — —	1 s on, 1 s off	PFEER Alarm, BS5839-1:2002	109	Tone 18	Tone 01
Tone 08	intermittent	970 (950)	— — — —	0,5 s on/0,5 s off x 3 dann 1,5 s off	ISO 8201 low tone, US Temporal	109	Tone 16	Tone 03
Tone 09	intermittent	800	— — — —	0,25 s on / 1 s off	Swedish Alarm SS 031711	107	Tone 27	Tone 03
Tone 10	intermittent	700	— — — —	0,15 s on / 0,15 s off, total 1 min.	Industrial alarm Germany	107	Tone 18	Tone 02
Tone 11	intermittent	720	— — — —	0,7 s on / 0,3 s off		108	Tone 02	Tone 29
Tone 12	intermittent	2400	— — — —	0,5 s on / 0,5 s off	ISO 8201 high tone, US Temporal	113	Tone 03	Tone 01
Tone 13	intermittent	2850	— — — —	0,5 s on / 0,5 s off x 3 dann 1,5 s off	AFNOR France, NFS 32-001	110	Tone 03	Tone 17
Tone 14	alternating	440 - 554	□ □ □ □	0,4 s (440Hz) / 0,1 s (554Hz)	Swedish Alarm	106	Tone 16	Tone 01
Tone 15	alternating	554 - 440	□ □ □ □	1 Hz		106	Tone 01	Tone 16
Tone 16	alternating	800 - 1000	□ □ □ □	2 Hz		109	Tone 02	Tone 09
Tone 17	alternating	2400 - 2900	□ □ □ □	2 Hz		113	Tone 03	Tone 01
Tone 18	alternating	1000 - 2000	□ □ □ □	1 Hz	Singapore	110	Tone 02	Tone 03
Tone 19	sweeping	500 - 1500	∧ ∧ ∧	10 Hz		109	Tone 02	Tone 01
Tone 20	sweeping	150 - 1000	∧ — — —	rising 10 s, 40 s on, falling 10 s	Industrial alarm Germany	109	Tone 01	Tone 29
Tone 21	continuous	400	—————	simulated Horn		104	Tone 16	Tone 02
Tone 22	sweeping	500 - 1200	∧ — — —	rising in 3,75 s / 0,25 s off	Australian evacuation AS 2220	109	Tone 02	Tone 09
Tone 23	sweeping	500 - 1200	∧ — — —	rising in 3,5 s / 0,5 s off	Netherlands NEN 2575:2000	109	Tone 02	Tone 09
Tone 24	sweeping	500 - 1200	∧ — — —	0,5 s on/0,5 s off x 3 / 1,5 s off	Australian evacuation AS1670	109	Tone 02	Tone 09
Tone 25	abfallend	1200 - 500	∨ — — —	1 Hz	German evacuation DIN 33404-3	109	Tone 02	Tone 32
Tone 26	sweeping	500 - 1200	∧ — — —	0,3 Hz		109	Tone 01	Tone 32
Tone 27	sweeping	1400 - 1600	∧ — — —	rising in 1 s/falling in 0,5 s	NFC 48-265	111	Tone 02	Tone 09
Tone 28	sweeping	2400 - 2900	∧ — — —	1 Hz		113	Tone 17	Tone 03
Tone 29	bell		□ □ □ □			109	Tone 16	Tone 02
Tone 30	slow rise	500 - 2400	∧ — — —	siren rising 3 s, then continuous 2400 Hz		113	Tone 16	Tone 01
Tone 31	slow rise	300 - 1200	∧ — — —	siren rising 3 s, then continuous 1200 Hz		110	Tone 16	Tone 01
Tone 32	chime	970 - 800	□ □ □ □	repeating ding-dong, 1 Hz		109	Tone 29	Tone 01

