

Autonics THUMBWHEEL SWITCH SETTING TYPE TEMPERATURE CONTROLLER T3/T4 SERIES

M A N U A L



Thank you for choosing our Autonics product.

Please read the following safety considerations before use.

■ Safety Considerations

- ※ Please observe all safety considerations for safe and proper product operation to avoid hazards.
- ※ Safety considerations are categorized as follows.
- Warning** Failure to follow these instructions may result in serious injury or death.
- Caution** Failure to follow these instructions may result in personal injury or product damage.
- ※ The symbols used on the product and instruction manual represent the following
- ▲ symbol represents caution due to special circumstances in which hazards may occur.

▲ Warning

- 1. Fail-safe device must be installed when using the unit with machinery that may cause serious injury or substantial economic loss.** (e.g. nuclear power control, medical equipment, ships, vehicles, railways, aircraft, combustion apparatus, safety equipment, crime/disaster prevention devices, etc.)
Failure to follow this instruction may result in personal injury, fire, or economic loss.
- 2. The unit must be installed on a device panel before use.**
Failure to follow this instruction may result in electric shock.
- 3. Do not connect, repair, or inspect the unit while connected to a power source.**
Failure to follow this instruction may result in electric shock.
- 4. Check the terminal numbers before connecting the power source.**
Failure to follow this instruction may result in fire.
- 5. Do not disassemble or modify the unit. Please contact us if necessary.**
Failure to follow this instruction may result in electric shock or fire.

▲ Caution

- 1. Do not use the unit outdoors.**
Failure to follow this instruction may result in shortening the life cycle of the unit, or electric shock. Use the unit indoors only. Do not use the unit outdoors, where it may be affected out external environmental factors.
- 2. When connecting the power input and relay output cables, use AWG20 (0.05mm²) cables and make sure to tighten the terminal screw bolt above 0.74N·m to 0.90N·m.**
Failure to follow this instruction may result in fire due to contact failure.
- 3. For crimp terminal, select the following shaped M3.5 terminals.**
- 4. Use the unit within the rated specifications.**
Failure to follow this instruction may result in shortening the life cycle of the unit, or fire.
- 5. Do not use loads beyond the rated switching capacity of the relay contact.**
Failure to follow this instruction may result in insulation failure, contact melt, contact failure, relay broken, or fire.
- 6. Do not use water or oil-based detergent when cleaning the unit. Use dry cloth to clean the unit.**
Failure to follow this instruction may result in electric shock or fire.
- 7. Do not use the unit where flammable or explosive gas, humidity, direct sunlight, radiant heat, vibration, or impact may be present.**
Failure to follow this instruction may result in fire or explosion.
- 8. Keep dust and wire residue from flowing into the unit.**
Failure to follow this instruction may result in fire or product damage.
- 9. Check the polarity of the measurement input contact before wiring the temperature sensor.**
Failure to follow this instruction may result in temperature measurement error.

■ Ordering Information

T	S	-	B	R	P	A	C	-	N
Unit	Upgrade		N		New type				
C	°C	F	°F	0	-99 to 199°C, -99.9 to 199.9°C				
1	0 to 99.9°C		2	0 to 200.0°C, 0 to 200.0°C					
2	0 to 400°C		4	0 to 800°C/°F					
8	0 to 999°C		A	0 to 1200°C					
C	0 to 1200°C		F	600 to 1600°C					
Input type ³⁾	J		J (IC)		K		K (CA)		
Control output ³⁾	R		Relay output		S		SSR drive output		
Power supply	4		100-240VAC 50/60Hz						
Control method	B		ON/OFF control, Proportional control						
Alarm/Sub output ³⁾	No mark		None						
A	Alarm output								
S	Sub output								
P	Dual setting output								
Size	M		DIN W48×H48mm (8-pin plug type) ³⁾						
S	M		DIN W72×H72mm						
H	M		DIN W48×H96mm						
L	M		DIN W96×H96mm						
Digit	3		999 (3 digit)						
4	9999 (4 digit)								
Item	T		Temperature Controller						

※ The above specifications are subject to change and some models may be discontinued without notice.

■ Specifications

Series	T3S	T3H	T3HA	T3HS	T4M	T4MA	T4L	T4LA	T4LP	
Power supply	100-240VAC 50/60Hz									
Allowable voltage range	90 to 110% of rated voltage									
Power consumption	Max. 5VA									
Display method	7 segment (red) LED method									
Character size (W×H)	3.8×7.8mm (8.0×10.0mm)							8.0×14.2mm		
Input type	RTD	DP1100Ω (Allowable line resistance max. 5Ω per a wire)								
TC	K (CA), J (IC)		K (CA), J (IC), R (PR)							
Display accuracy ¹⁾	RTD	±0.1 room temperature (23°C ± 5°C); (PV ± 0.5% or ±1°C, select the higher one) ± 1 digit								
TC	±0.2 of room temperature range; (PV ± 0.5% or ±2°C, select the higher one) ± 1 digit									
Control output	Relay	OUT1: 250VAC 5A 1c, OUT2: 250VAC 2A 1c ²⁾								
SSR	Max. 12VDC±2V 20mA									
Current	DC4-20mA (resistive load max. 500Ω)									
Alarm/Sub Dual setting output				250VAC 2A 1c					250VAC 2A 1c	
Control method	ON/OFF, Proportional control									
Hysteresis	F.S. 0.5%		F.S. 0.2 to 3% variable							
Proportional band	F.S. 3%		F.S. 1 to 10% variable							
Proportional cycle	20 sec.									
RESET range	F.S. -3 to 3% variable									
Relay Mechanical	Over 5,000,000 times									
life cycle Electrical	OUT1: Over 100,000 times, OUT2: Over 200,000 times									
Dielectric strength	2,000VAC 50/60Hz 1min. (between input terminal and power terminal)									
Vibration	0.75mm amplitude at frequency of 10 to 55Hz (for 1 min.) in each X, Y, Z direction for 2 hours									
Insulation resistance	Min. 100MΩ (at 500VDC megger)									
Noise	Square-wave noise by noise simulator (pulse width 1μs) ±2kV R-phase and S-phase									
Memory retention	Approx. 10 years (when using non-volatile semiconductor memory type)									
Environment	Ambient temperature	-10 to 50°C, Storage: -20 to 60°C								
Ambient humidity	35 to 85% RH, Storage: 35 to 85% RH									
Weight ³⁾	Approx. 135g (approx. 95g)	Approx. 239g (approx. 176g)	Approx. 246g (approx. 180g)	Approx. 310g (approx. 222g)						

- ※ 1: In case of the T3S Series and the decimal point display models
At room temperature (23°C±5°C): (PV ±0.5% or ±2°C, select the higher one) ±1 digit
Out of room temperature range: (PV ±0.5% or ±3°C, select the higher one) ±1 digit
- ※ 2: Dual setting output of the T4LP is fixed as relay output and it is available as alarm output.
- ※ 3: The weight is with packaging and the weight in parentheses is only unit weight.
- ※ Environment resistance is rated at no freezing or condensation.

■ Unit Description

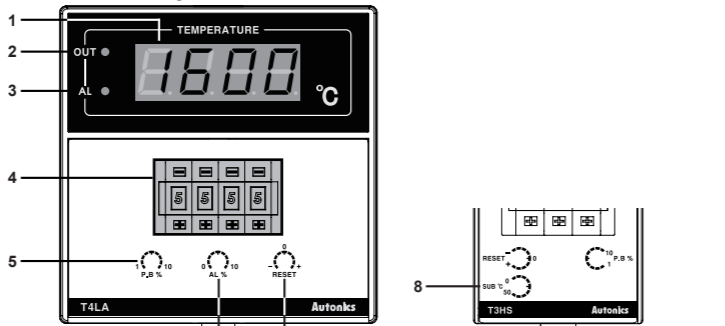

- 1. Present temperature (PV) display**
It displays present temperature.
- 2. Control output (OUT) indicator**
It turns ON when control output is ON.
※ In case of the T3S, the upper DOT of last digit flashes.
- 3. Alarm output (AL) indicator**
It turns ON when alarm output is ON. (only for alarm output model)
In case of the sub output model (T3HS), the sub (SUB) indicator turns ON when sub output is ON.
- 4. Set value (SV) thumbwheel switch**
Switch for setting temperature.
(-) button: Decreases number, (+) button: Increases number
If the setting is out of the temperature range of temperature sensor, the present temperature (PV) display part flashes 5uE- and the present value in turn.
※ The models which temperature range is 0 (-99.9 to 199.9°C, -99 to 199°C) of temperature sensor DP1100 are only set 1~4 (-).
※ The dual setting output model (T4LP) has two thumbwheel switches.
LO SET (low set output), HI SET (high set output)
- 5. Hysteresis/Proportional width volume switch (except T3S)**
ON/OFF control: Setting for hysteresis. [Setting range] F.S. 0.2 to 3% (For T3S, F.S. 0.5% fixed)
Proportional control: Setting for proportional width.
[Setting range] F.S. 1 to 10% (For T3S, F.S. 3% fixed)
Proportional cycle: 20 sec. fixed
- 6. Alarm output value volume switch**
It sets alarm output value. (only for alarm output model) [Setting range] F.S. 0 to 10%
- 7. RESET volume switch**
In case of proportional control, it sets offset. [Setting range] F.S. -3 to 3%
- 8. Temperature setting of sub output volume switch (only for T3HS)**
It sets temperature of the sub output. This output operates as deviation low-limit alarm based on the set sub-output temperature (SV). [Setting range] 0 to 50°C

※ 1: Socket (PG-08, PS-08(N)) is sold separately.

※ 2: Output by Series

Series	T3S	T3H	T3HA	T3HS	T4M	T4MA	T4L	T4LA	T4LP
Control output	●	●	●	●	●	●	●	●	●
Control ¹⁾	●	●	●	●	●	●	●	●	●
Alarm/Sub output	●	●	●	●	●	●	●	●	●
Dual setting output	●	●	●	●	●	●	●	●	●

Input type	Model	T3S	T3H	T3HA	T3HS	T4M	T4MA	T4L	T4LA	T4LP
K (CA)	0 to 400°C	●	●	●	●	●	●	●	●	●
	0 to 800°C	●	●	●	●	●	●	●	●	●
	0 to 1200°C	●	●	●	●	●	●	●	●	●
J (IC)	0 to 200°C	●	●	●	●	●	●	●	●	●
	0 to 400°C	●	●	●	●	●	●	●	●	●
	0 to 800°C	●	●	●	●	●	●	●	●	●
R (PR)	600 to 1600°C	●	●	●	●	●	●	●	●	●
	-99 to 199°C	●	●	●	●	●	●	●	●	●
DP1100Ω	0 to 99.9°C	●	●	●	●	●	●	●	●	●
	0 to 200.0°C	●	●	●	●	●	●	●	●	●
	0 to 400°C	●	●	●	●	●	●	●	●	●

※ 1: T4LP (Dual setting output) is the single output.

※ 2: When 5uE- and oPE- / HHHH, LLL occur at the same time, 5uE- and oPE- / HHHH, LLL flash in turn and all output turns OFF.

■ Control Method (ON/OFF, proportional control) Setting

Before supplying power, remove the case and set the control method by the control method setting switch.

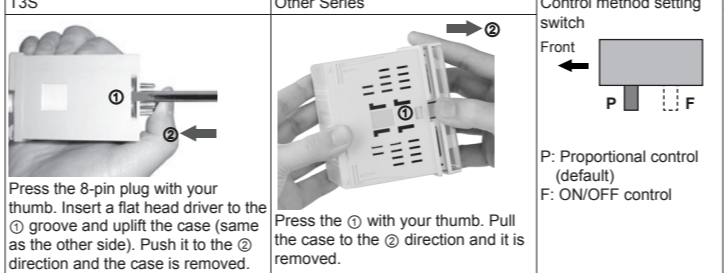

■ Function

- 1) ON/OFF control**
Comparing the present measured temperature and the set temperature, the temperature controller turns ON/OFF of the load power. Interval between ON and OFF of control output is set by the set hysteresis. When hysteresis of control output is too narrow, hunting (overshoot, chattering) may occur by external noise.
[Setting range of Hysteresis] F.S. 0.2 to 3% (In case of T3S, F.S. 0.5% fixed)
- 2) Proportional control**
Proportional control has control output which is proportional to deviation from the present temperature to the set temperature in the proportional band to the set temperature.
[Setting range of Proportional band] F.S. 1 to 10% (In case of T3S, F.S. 3% fixed)
[Setting range of RESET] F.S. -3 to 3%
- 3. Sub output (Only for T3HS)**
Only the T3HS model has sub output. This output operates as deviation low-limit alarm.
[Setting range of Sub output] 0 to 50°C
E.g.) Set temperature is set as 100°C and sub-output is set as 20°C
- 4. Dual setting output (Only for T4LP)**
Only the T4LP model has dual setting output.
-LO SET (low set output): ON/OFF control (Hysteresis: F.S. 0.2 to 3%)
Proportional control (Proportional band: F.S. 1 to 10%)
-HI SET (high set output): Absolute value high-limit alarm output (Hysteresis: 2°C fixed)
E.g.) T4LP, temperature sensor: DP110, temperature range: 0 to 400°C

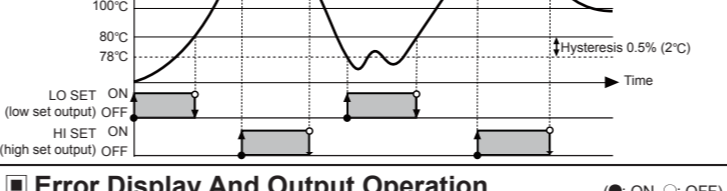
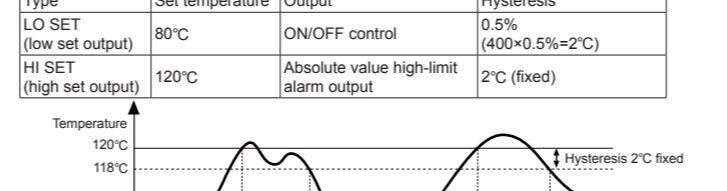
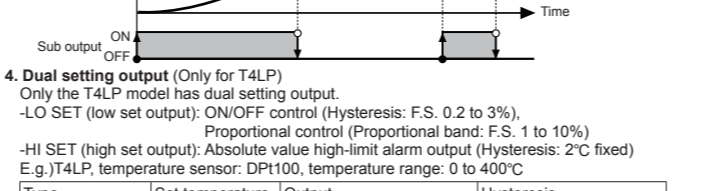
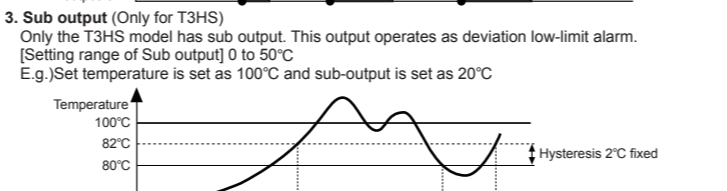
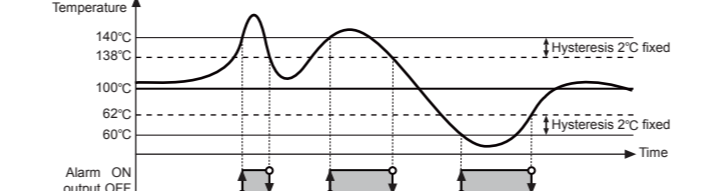
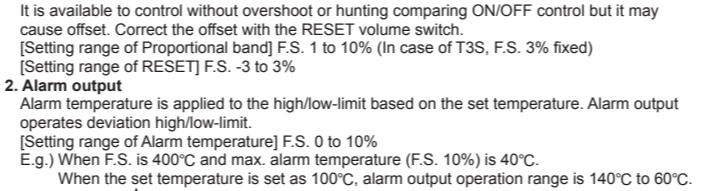

■ Error Display And Output Operation

Display	Description	Control output ¹⁾	Alarm output ²⁾	Sub output	Dual output	Troubleshooting
oPE-	Flashes when a temperature sensor is broken or not connected.	○	●	○	●	Check the status of the temperature sensor. When the sensor is connected correctly, it is clear.
HHHH	Flashes when the measured input value is higher than the temperature range of the sensor.	○	○	○	○	When the measured temperature is within the temperature range of the sensor, it is clear.
LLLL	Flashes when the measured input value is lower than the temperature range of the sensor.	○	○	○	○	The set value should be within the temperature range of the sensor.
5uE-	Flashes with the present value when the set value is out of the temperature range of the sensor.	○	○	○	○	

※ 1: T4LP (Dual setting output) is the single output.

※ 2: When 5uE- and oPE- / HHHH, LLL occur at the same time, 5uE- and oPE- / HHHH, LLL flash in turn and all output turns OFF.

■ Dimensions

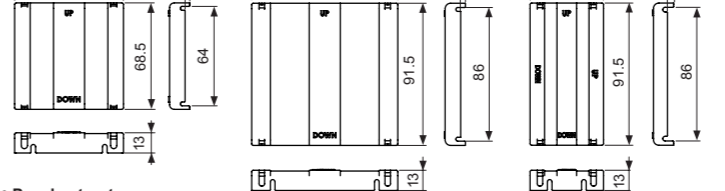
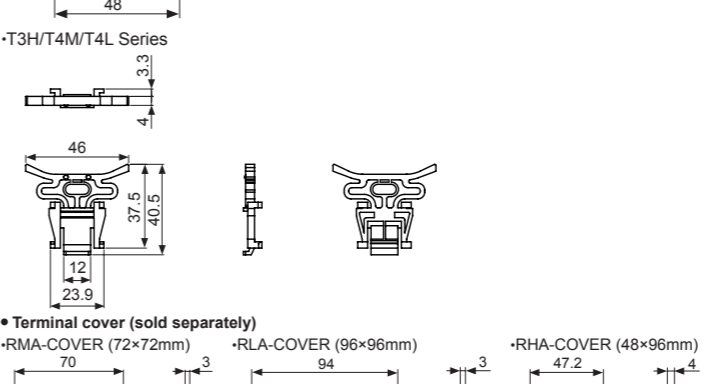
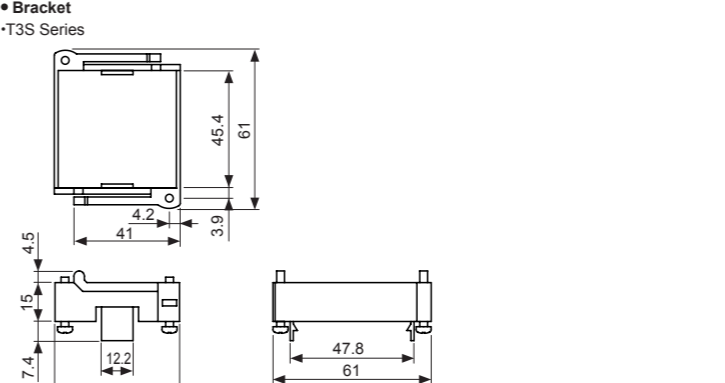
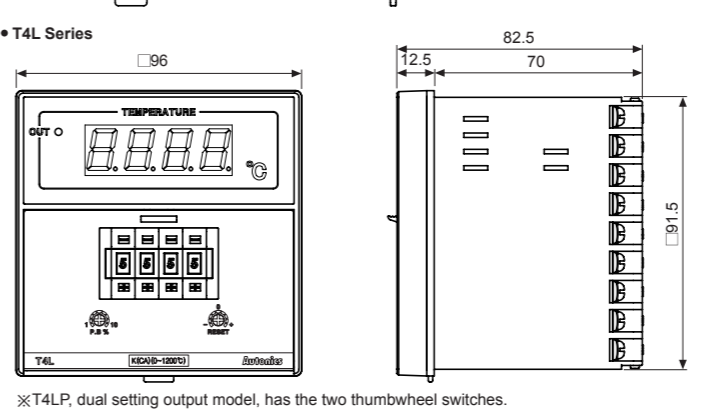
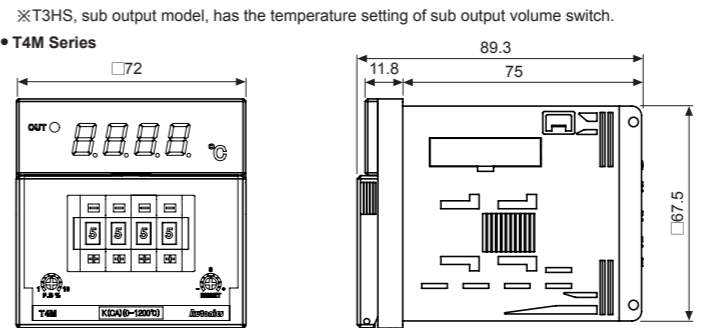
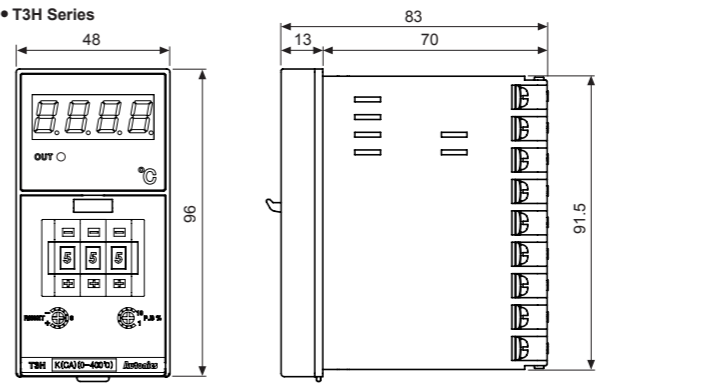
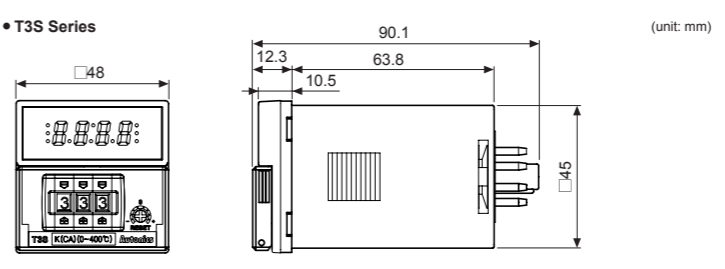

Series	Size	A	B	C	D
T3S	Min. 65	Min. 65	45 ^{±0.2}	45 ^{±0.2}	
T3H	Min. 65	Min. 115	45 ^{±0.2}	92 ^{±0.2}	
T4M	Min. 90	Min. 90	68 ^{±0.2}	68 ^{±0.2}	
T4L	Min. 115	Min. 115	92 ^{±0.2}	92 ^{±0.2}	

■ Connection

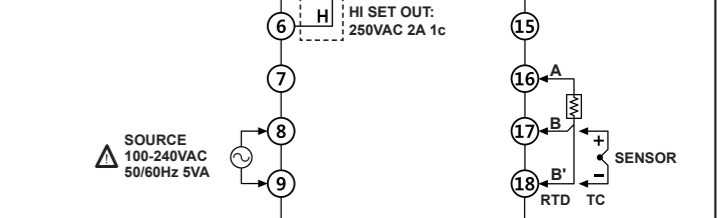
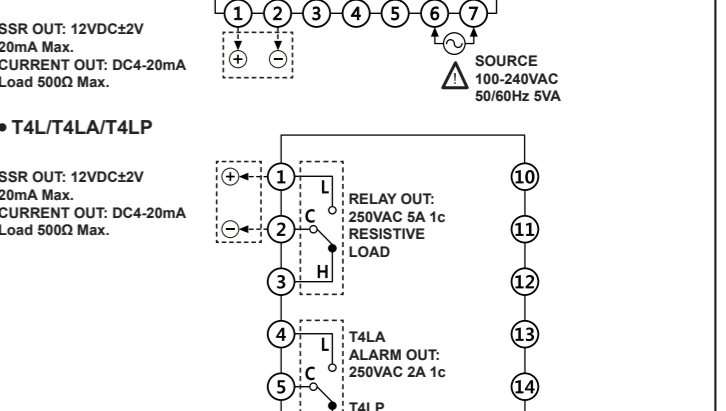
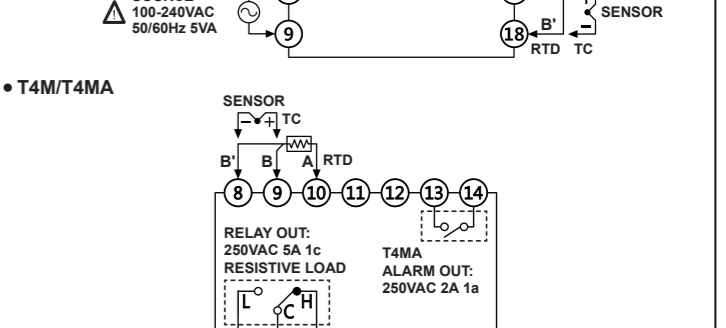
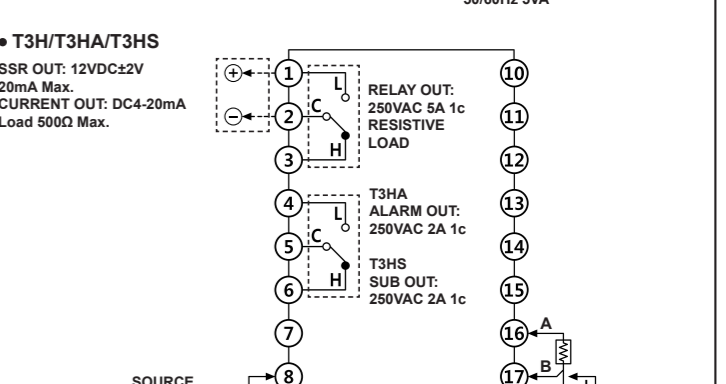
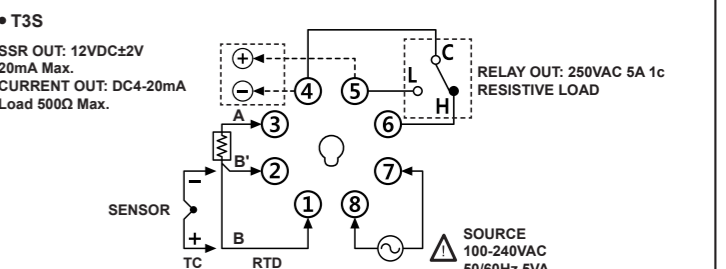

■ Display When Power Is ON

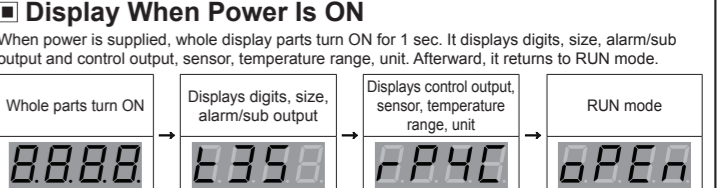

■ Caution During Use

- Please use separated line from high voltage line or power line in order to avoid inductive noise.
- Please install power switch or circuit-breaker in order to cut power supply off.
- The switch or circuit-breaker should be installed near by users.
- This unit is designed for temperature controlling only. Do not apply this unit as a voltage meter or a current meter.
- In case of using RTD sensor, 3-wire type must be used. If you need to extend the line, 3-wire must be used with the same thickness as the line. It might cause temperature difference if the resistance of line is different.
- In case of making power line and input signal line close, line filter for noise protection should be installed at power line and input signal line should be shielded.
- Keep away from the high frequency instruments. (high frequency welding machine & sewing machine, big capacitive SCR controller).
- This unit may be used in the following environments.
① It shall be used indoor. ② Altitude up to 2,000m.
③ Installation category II.
- ※ Failure to follow these instructions may result in product damage.

■ Major Products

- Photoelectric sensors
- Fiber optic sensors
- Door sensors
- Door side sensors
- Area sensors
- Proximity sensors
- Pressure sensors
- Rotary encoders
- Connector/sockets
- Switching mode power supplies
- Control switches/Lamps/Buzzers
- Terminal blocks & cables
- Stepper motors/drivers/motion controllers
- Graphic logic panels
- Field network devices
- Laser marking system (Fiber, CO₂, Nd:YAG)
- Laser welding/cutting system
- Temperature controllers
- Temperature/humidity transducers
- SSR/Power controllers
- Counters
- Timers
- Panel meters
- Tachometer/Pulse (Rate) meters
- Display units
- Sensor controllers
- Temperature controllers
- Control switches/Lamps/Buzzers
- Terminal blocks & cables
- Stepper motors/drivers/motion controllers
- Graphic logic panels
- Field network devices
- Laser marking system (Fiber, CO₂, Nd:YAG)
- Laser welding/cutting system

Autonics corporation
http://www.autonics.com
Trusted Partner In Industrial Automation

HEADQUARTERS:
18, Bamsong-ro 513beon-gil, Haeundae-gu, Busan, Korea.
OVERSEAS SALES:
#402-404, Bucheon Techno Park, 655, Pyeongcheon-ro, Woomi-gu, Bucheon, Gyeonggi-do, Korea.
TEL: 82-32-610-2700 / FAX: 82-32-329-0728
E-mail: sales@autonics.com

EP-KE-03-0390A